

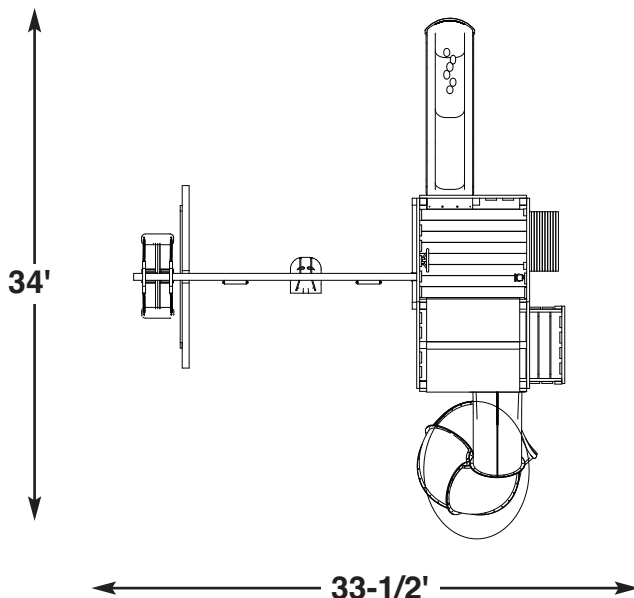
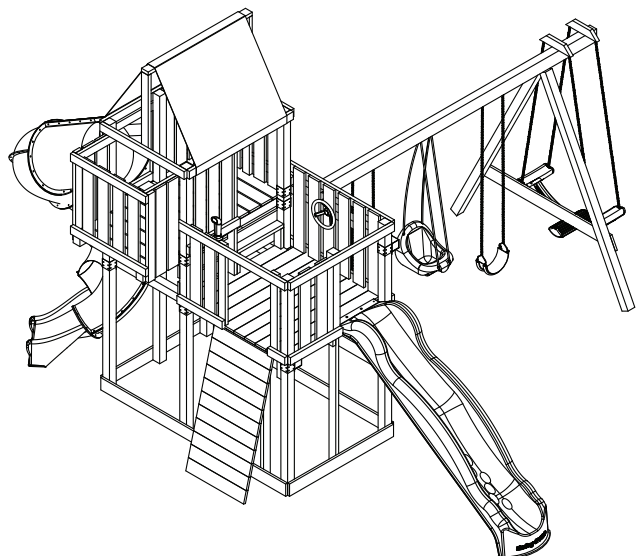


NE 5010

We Put Kids First.

# Kodiak™

PROJECT 514



<p><b>No. of Children:</b> Up to 10  <b>Min. Use Zone:</b> 34' x 33-1/2'  <b>Set Dim.</b> 22'W x 21-1/2'L x 14'H  <b>Est. Building Time:</b> 5-10 hr.</p>
---

check out <http://www.swing-n-slide.com/planupdates.htm> for updates to these instructions.



## ASSEMBLY INSTRUCTIONS

Swing-N-Slide • 1212 Barberry Drive • Janesville, Wisconsin 53545  
Visit our web site at: [www.swing-n-slide.com](http://www.swing-n-slide.com) or call us at 1-800-888-1232



We Put Kids First.

## Safety Checklist for Swing-N-Slide Accessories

Observing the following statements and warnings reduces the likelihood of serious or fatal injury

### Installation Safety – Have You:

- Consulted the assembly instructions supplied with your particular model?
- Noted this accessory is to be used only on Swing•N•Slide approved designs? (Do not alter its design or add/remove components.)
- Made sure all hardware is tightened securely? (Supplied bolt covers must also be fastened securely.)
- Using a hacksaw, cut off all protruding threaded ends of bolts and other fasteners and remove any sharp edges with a metal file as needed?
- Placed the equipment on level ground, not less than six feet (1.8 meters) from any structure or obstruction such as a fence, garage, house, overhanging branches, laundry lines, or electrical wires?
- Made sure home playground equipment is not installed over concrete, asphalt, packed earth or any other hard surface? (A fall onto a hard surface can result in serious injury to the equipment user.)
- Verified that suspended climbing ropes, chain, or cable are secured at both ends?
- Consulted in assembly instructions of your particular model for minimum use zones?
- Followed all anchoring and shock absorbing surfacing requirements later in this guide as they apply?
- Made sure not to allow children to use equipment until it is properly installed?

### Operating Safety – Have You:

- Determined that on-site adult supervision is provided for children of all ages?
- Warned children the following before allowing them to use the equipment?
  - Not to walk close to, in front of, behind or between moving items.
  - Not to twist swing or any other accessory chains or ropes or loop them over the top support bar since this will reduce the strength of chain or rope.
  - Not to swing empty seats or other accessories.
  - Be sure to sit in the center of the swing seat and other accessories with full weight on the seat.
  - Not to attach items to the playground equipment that are not specifically designed for use with the equipment such as but not limited to, jump ropes, clotheslines, pet leashes, cables and chain. They may cause a strangulation hazard.
  - Not to use equipment in a manner other than intended.
  - Not to get off equipment while it is in motion.
  - Not to climb on the equipment when it is wet.
- Determined that only one child per planned occupant seat should be allowed on this set at one time.
- Determined children must be dressed appropriately for play. Avoid clothing with draw strings and loose fitting clothes which could become entangled or snagged on equipment.
- Determined that suspended climbing ropes, chain, or cable cannot be looped back upon itself.
- Read and understood the following warning regarding the use of two and four passenger lawn swings?

**Warning:** Lawn Swings are designed for use by children over two years of age. Use by children under the age of two can result in entrapment between the seats and back areas. **Never** place children in a rearward facing position or with legs between the seat and backrest because the child's body may pass through the opening causing entrapment of the child's head.

### Safety Maintenance – Have You Determined to:

- Check all nuts and bolts twice monthly during the usage season for tightness and tighten as required? (It is particularly important that this procedure be followed at the beginning of each season.)
- To prevent the deterioration of materials, remove plastic swing seats and other plastic accessories and take indoors? (Do not use when the temperature drops below 0° F.)
- Oil all metallic moving parts monthly during usage period?
- Check all hardware and equipment for sharp edges twice monthly during usage season? (Replace when necessary. It is especially important to do this at the beginning of each new season.)
- Check swing seats, chains, ropes and cables monthly during usage season for evidence of deterioration? Severe rusting or excessive wear, especially near the top swing hanger or at the seat connection are evidence of chain deterioration. Cracks in the protective plastic sleeve or seat itself are also signs of deterioration. If any of these conditions exist, call 1-800-888-1232 to order replacement accessories.

### Disposal Instructions

When the equipment is taken out of service, it must be disassembled and disposed of in such a way that no unreasonable hazards will exist at the time the set is discarded.

**Important! Additional Safety Instructions for all Swing-N-Slide Playground Equipment.  
Save this instruction sheet in the event the manufacturer needs to be contacted.**

## SAFETY INSTRUCTIONS

## INSTRUCCIONES DE SEGURIDAD

## INSTRUCTIONS CONCERNANT LA SÉCURITÉ

**IMPORTANT!** *This product is intended for single family residential use only and not intended for use in any public setting. Placement in any public setting constitutes a misuse of this product.*

### REQUIRED SAFETY INSTALLATION INSTRUCTIONS

• Once the unit is completely assembled and before children are allowed to play on it, proper shock-absorbing surfacing material must be installed. This may be accomplished by using loose-fill materials at a sufficient depth. The Consumer Product Safety Commission "Handbook for Public Playground Safety" lists the following materials and required depths that are sufficient for home/residential application. For fall height protection up to 9 ft. (2.742m) [recommended for Swing·N·Slide kits]:

LOOSE FILL MATERIAL	REQUIRED DEPTH ' INCH (mm) (UNCOMPRESSED)
Wood Mulch	9" (229mm)
Double Shredded Bark Mulch	9" (229mm)
Uniform Wood Chips	12" (305mm)
Fine Sand	12" (305mm)
Fine Gravel	12" (305mm)

1 These depths were derived from the CPSC Handbook. Swing·N·Slide has not done independent tests to determine these required depths.

When properly installed, shock absorbing material will completely cover the horizontal baseboards on climbing units. This protective surfacing must extend a **minimum** of 6 ft. (1.828m) in all directions from the perimeter of the equipment or from the outermost edges of any component. For example, a slide extending beyond the platform must have protective surfacing at least 6 ft. (1.828m) out from both sides as well as the end. For swings, the protective surface must extend **at least 14 ft.** out from **both** the back and front of the swing when the swing is in its rest position.

**¡IMPORTANTE!** *Este producto es para ser usado por una sola familia en uso residencial y no para usarse en ningún lugar público. El ubicarlo en cualquier lugar público constituye mal uso de este producto.*

### INSTRUCCIONES REQUERIDAS PARA LA INSTALACIÓN CON SEGURIDAD

• Una vez que se haya armado la unidad completamente y antes que se permita a los niños que la usen, se debe instalar un material que amortigüe para la superficie del suelo. Esto se puede conseguir usando materiales que llenen flojamente a una profundidad suficiente. El "Folleto para la Seguridad Pública en Campos de Recreo" de la Comisión de Seguridad de Producto al Cliente, permite los siguientes materiales y las profundidades requeridas que sean lo suficiente para una aplicación en situaciones de residencias. Para protección contra caídas se necesita hasta 9 pies (2,742m) [recomendadas para los conjuntos Swing·N·Slide]:

MATERIAL DE APLICACIÓN FLOJA	PROFUNDIDAD REQUERIDA' PULGADA mm (SIN SER COMPRIMIDA)
Viruta de madera	9" (229mm)
Viruta trizada de corteza de árbol	9" (229mm)
Trozos pequeños uniformes de madera	12" (305mm)
Arena fina	12" (305mm)
Grava fina	12" (305mm)

1 Estas profundidades fueron derivadas del folleto CPSC. Swing·N·Slide no ha hecho pruebas independientes para determinar las requeridas profundidades.

Cuando se instale apropiadamente, el material que amortigüe completamente cubrirá la base horizontal de las unidades de preparar. Esta superficie protectora debe extenderse un **mínimo** de 6 pies (1,828m) en todas las direcciones desde el perímetro del equipo, o de los bordes más salientes de cualquier componente. Por ejemplo, un tobogán que se extiende más allá de la plataforma debe tener una superficie protectora de por lo menos 6 pies (1,828m) más allá de ambos lados, al igual que desde el extremo. Para columpios, la superficie protectora debe extenderse **por lo menos 14 pies** más allá de **ambos**, de la parte de atrás, y la parte frontal del columpio, cuando el columpio esté en una posición neutra.

**IMPORTANT!** *Ce produit est conçu uniquement pour un usage résidentiel. Il ne saurait aucunement convenir aux installations publiques.*

### L'UTILISATION DANS UN ENDROIT PUBLIC CONSTITUE UN USAGE ABUSIF DU PRODUIT.

• Lorsque l'unité est entièrement assemblée, un matériau de protection amortisseur doit être installé sur le sol avant de permettre aux enfants de s'amuser. Des matériaux particuliers d'une épaisseur suffisante peuvent être utilisés à cette fin. Le guide américain intitulé « Handbook for Public Playground Safety » rédigé par la Consumer Product Safety Commission (CPSC) des États-Unis recommande une liste de matériaux et spécifie l'épaisseur requise pour un usage résidentiel. Protection contre les chutes d'une hauteur de 9 pieds (2,742 m) [recommandation pour les unités Swing·N·Slide] :

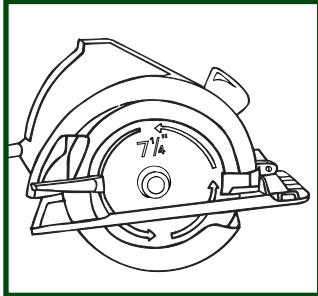
MATÉRIAUX PARTICULAIRES	ÉPAISSEUR RECOMMANDÉE' EN PO (mm) (NON COMPRIMÉ)
Paillis de bois	9 po (229mm)
Paillis d'écorce filantée	9 po (229mm)
Copeaux de bois uniformes	12 po (305mm)
Sable fin	12 po (305mm)
Gravier fin	12 po (305mm)

1 Ces valeurs sont tirées du guide de la CPSC. Les unités Swing·N·Slide n'ont pas fait l'objet d'essais indépendants afin de déterminer l'épaisseur recommandée des matériaux.

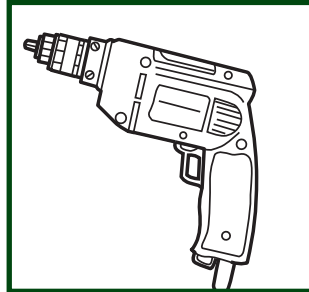
Pour que l'installation soit adéquate, le matériau amortisseur doit recouvrir entièrement la base horizontale des unités d'escalade. Un matériau de protection doit entourer l'installation sur une surface **d'au moins 1,828 m (6 pieds)** à partir du pourtour de l'unité ou des composants les plus éloignés. Par exemple, une glissoire qui se prolonge au-delà de la plate-forme doit être pourvue d'une surface de protection d'au moins 1,828 m (6 pieds) de chaque côté ainsi qu'à l'extrémité. En ce qui concerne les balançoires, la zone de protection doit couvrir **au moins 14 pi (6 m)** autant devant que derrière la balançoire lorsque celle-ci est immobile.

# PROJECT 514

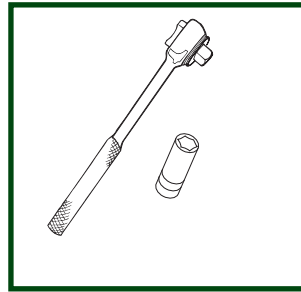
## TOOLS REQUIRED



CIRCULAR SAW



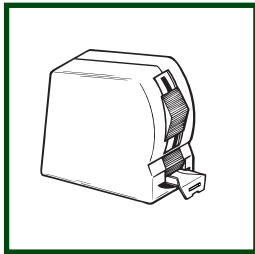
ELECTRIC DRILL



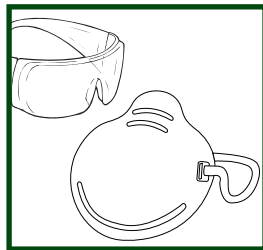
1/2" SOCKET & WRENCH



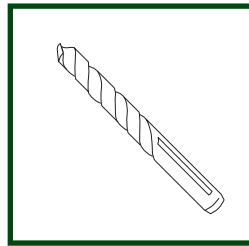
HAMMER



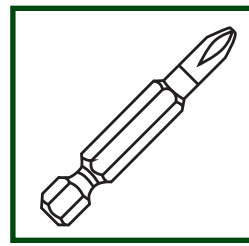
TAPE MEASURE



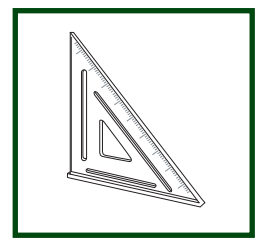
SAFETY GLASSES  
& DUST MASK



3/8" DRILL BIT (6" Min.)



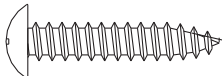
PHILLIPS BIT



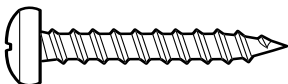
CARPENTER'S SQUARE



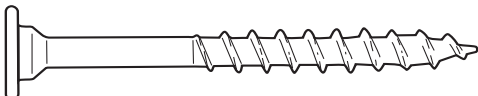
(2) 1/2" panhead screws



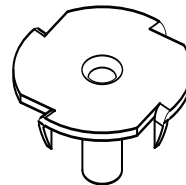
(4) 1" Truss Screws



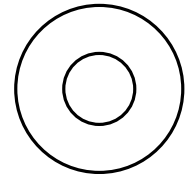
(8) 1-3/4" panhead screws



(111) 2" lag screw



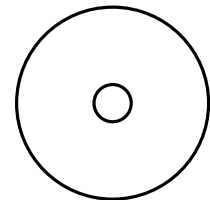
(6) T- nuts



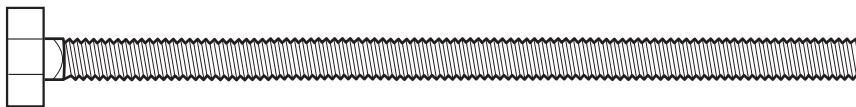
(10) 5/16" flat washers



(4) 1/4" flat washers



(6) Tarp Washers



(2) 5-1/2" Bolts

**PURCHASED  
SEPARATELY**



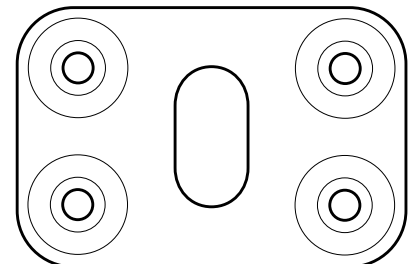
(64) 1-1/4" screws



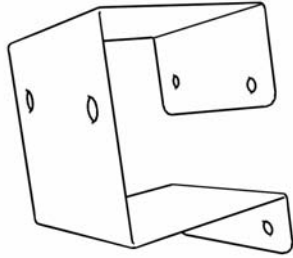
(127) 2" screws



(453) 2-1/2" screws

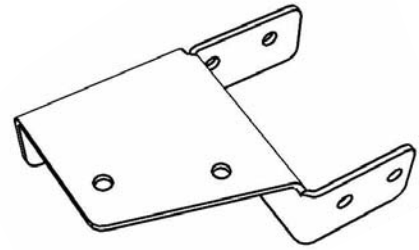


(4) Clamp Slotted

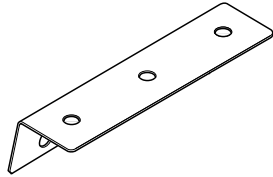


(12) Shelf-Loc

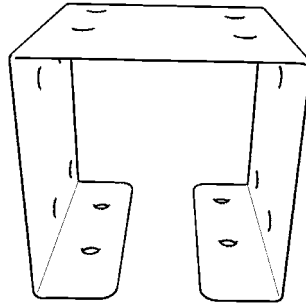
## Rapid Loc™ System



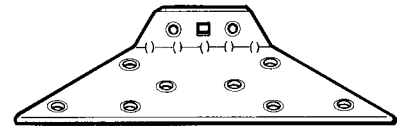
(2) Split Beam bracket



(10) Step Brackets  
Note: (5 Left, 5 Right)



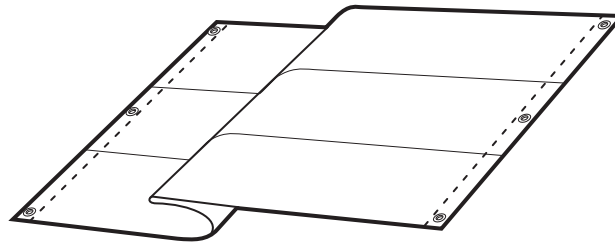
(12) Wrap-Loc



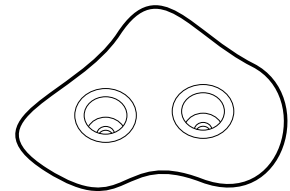
(2) EZ Frame Brackets



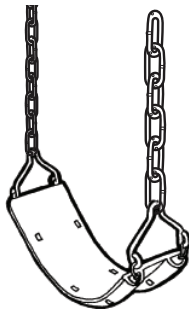
(1) Name Plate



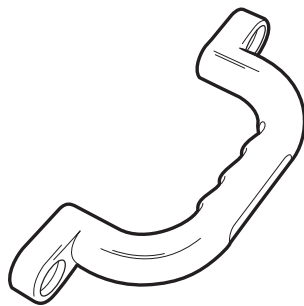
(1) Multicolor Tarp



(4) Climbing Rocks  
with Hardware



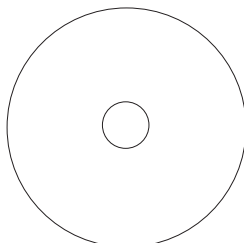
(2) Swing Seats  
weight limit: 115 lbs.



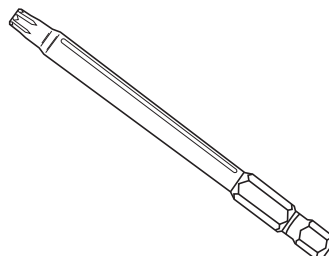
(4) Safety Handles



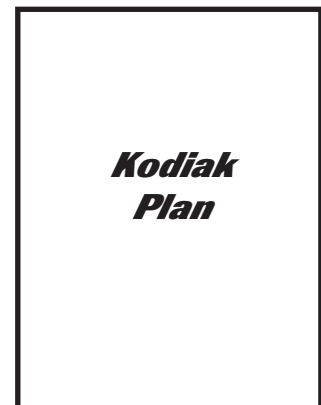
(4) Swing Hangers



(1) Instructional DVD



(1) T30 Torx® Bit

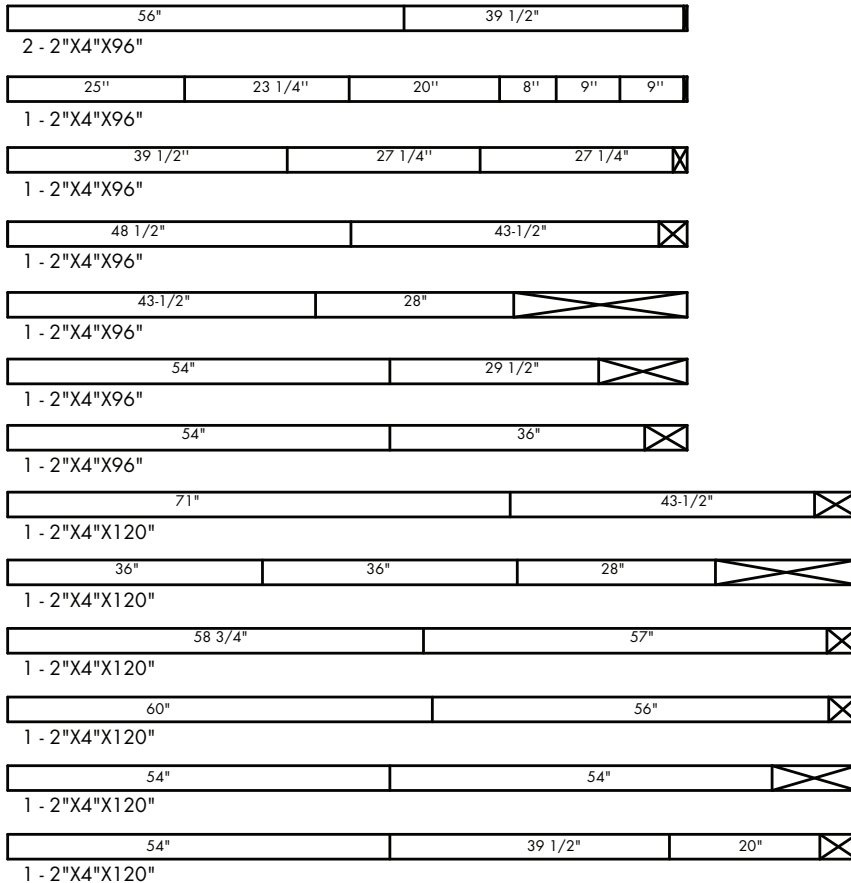


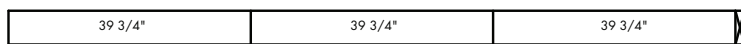
(1) Plan

# PROJECT 514

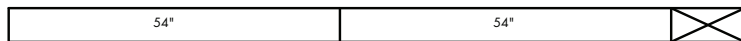
## KODIAK 514

8 - 2"x4"x96"	OPTIONAL LADDER
6 - 2"x4"x120"	2 - 2"x4"x96"
12 - 5/4"x6"x120"	2 - 2"x4"x120"
10 - 5/4"x6"x144"	OPTIONAL ROCK WALL
9 - 4"x4"x96"	2 - 2"x4"x96"
5 - 4"x4"x120"	1 - 2"x4"x120"
1 - 4"x6"x144"	3 - 5/4"x6"x120"
or	
2 - 2"x6"x144"	

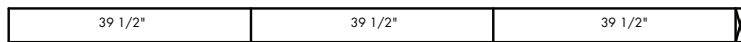




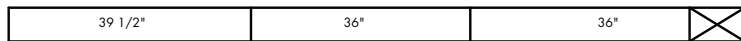
1 - 5/4"X6"X120"



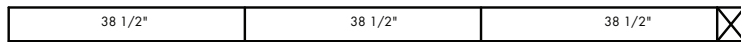
6 - 5/4"X6"X120"



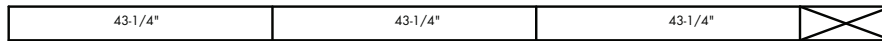
1 - 5/4"X6"X120"



1 - 5/4"X6"X120"



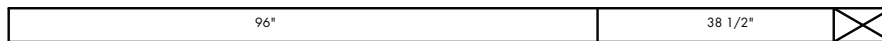
3 - 5/4"X6"X120"



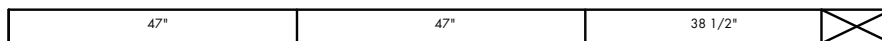
1 - 5/4"X6"X144"



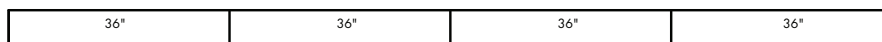
1 - 5/4"X6"X144"



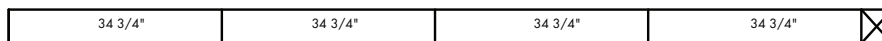
3 - 5/4"X6"X144"



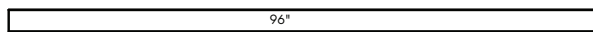
1 - 5/4"X6"X144"



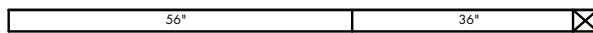
3 - 5/4"X6"X144"



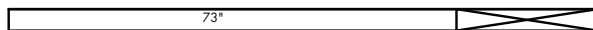
1 - 5/4"X6"X144"



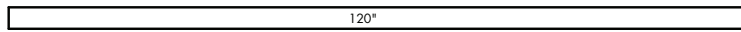
6 - 4"X4"X96"



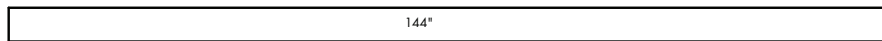
1 - 4"X4"X96"



2 - 4"X4"X96"

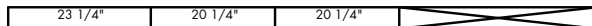


5 - 4"X4"X120"



1 - 4"X6"X144" OR 2 - 2"X6"X144"

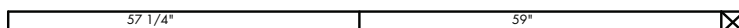
### OPTIONAL LADDER



1 - 2"X4"X96"



1 - 2"X4"X96"



2 - 2"X4"X120"

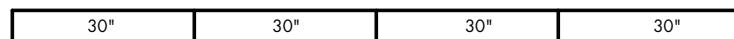
### OPTIONAL ROCK WALL



2 - 2"X4"X96"



1 - 2"X4"X120"



3 - 5/4"X6"X120"

# PROJECT 514

## How to select the correct fastener

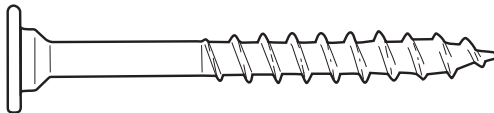
Use these 3 pictorial guides to help select the correct fastener(s) for the lumber attachment you are making. Each diagram will highlight the correct number of fasteners to use, and where to attach them.

### 5/4" x 6" to 4" x 4"



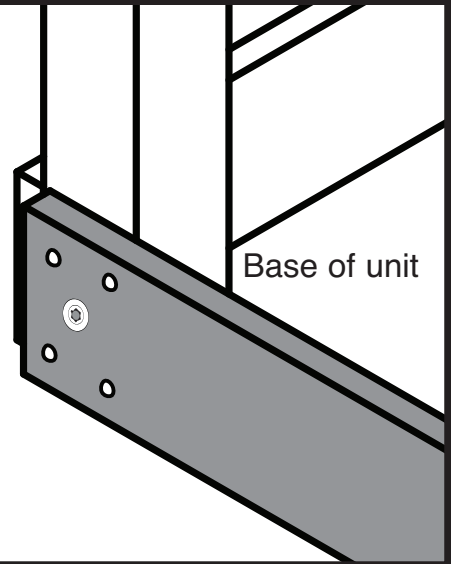
#### (4) 2-1/2" screws

Apply the 2-1/2" screws to secure the 5/4" boards to the 4" x 4" uprights as shown.



#### (1) 2" lag screw

After attaching the 2 1/2" screws, apply the center (1) 2" lag screw as shown for additional support.

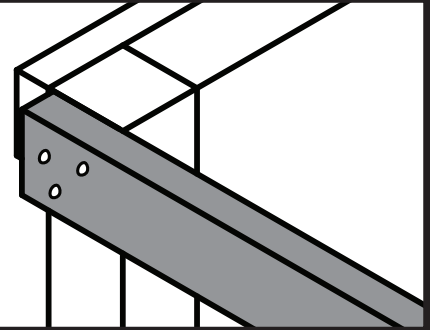


### 2" x 4" to 4" x 4"



#### (3) 2-1/2" screws

Apply 2 1/2" screws to the 2" x 4" boards when attaching to 4" x 4" uprights.

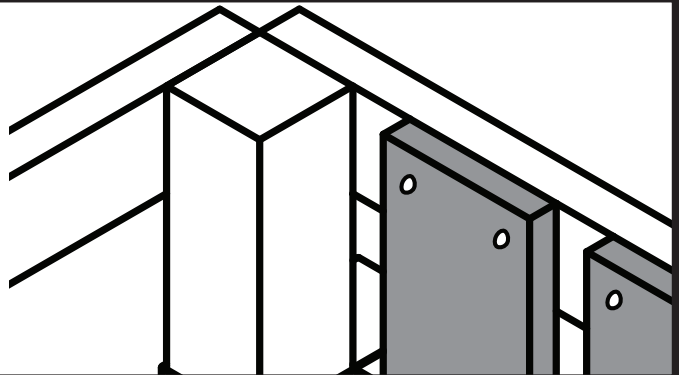


### 5/4" x 6" to 2" x 4"



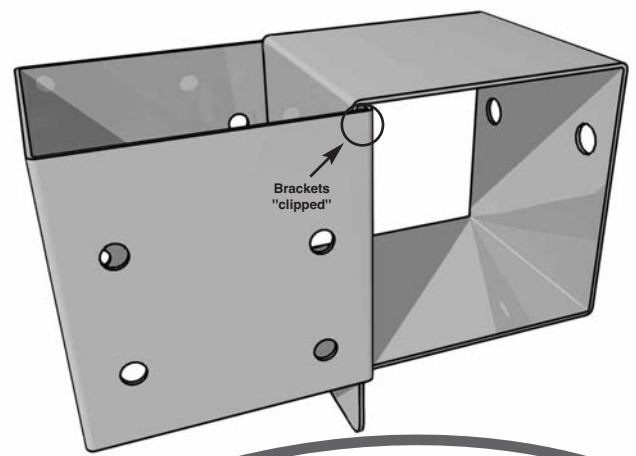
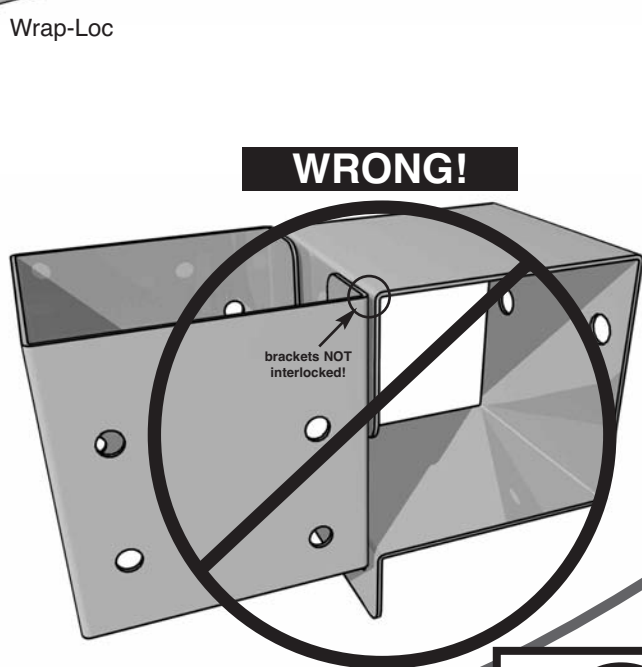
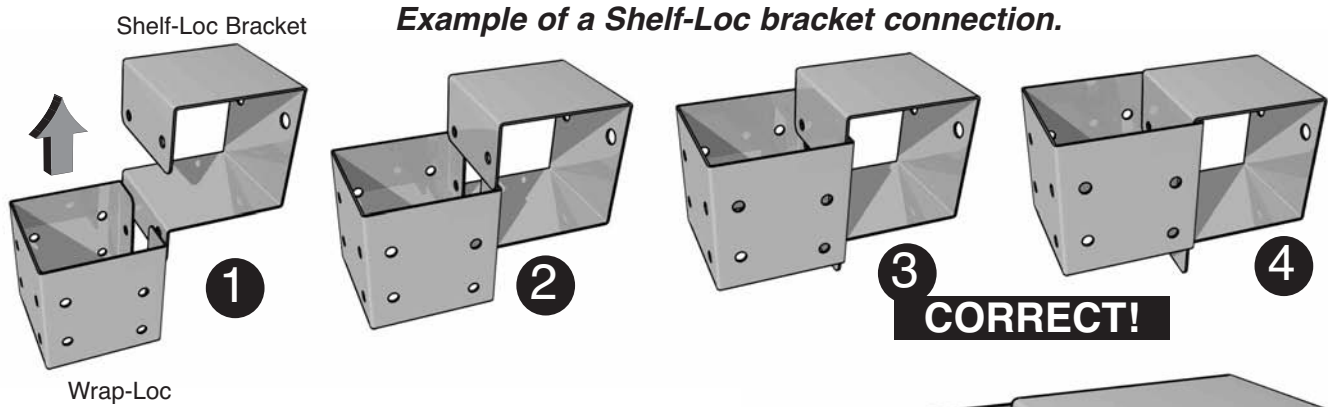
#### (2) 2" screws

Use 2" screws when mounting 5/4" boards to 2" x 4" boards.



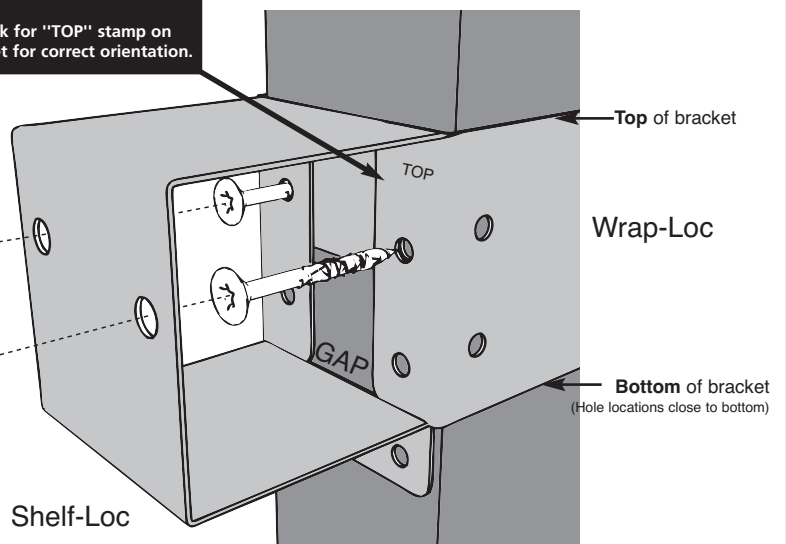


# Understanding how the Bracket System Works



Example of a Shelf-Loc bracket connection.

 Look for "TOP" stamp on bracket for correct orientation.

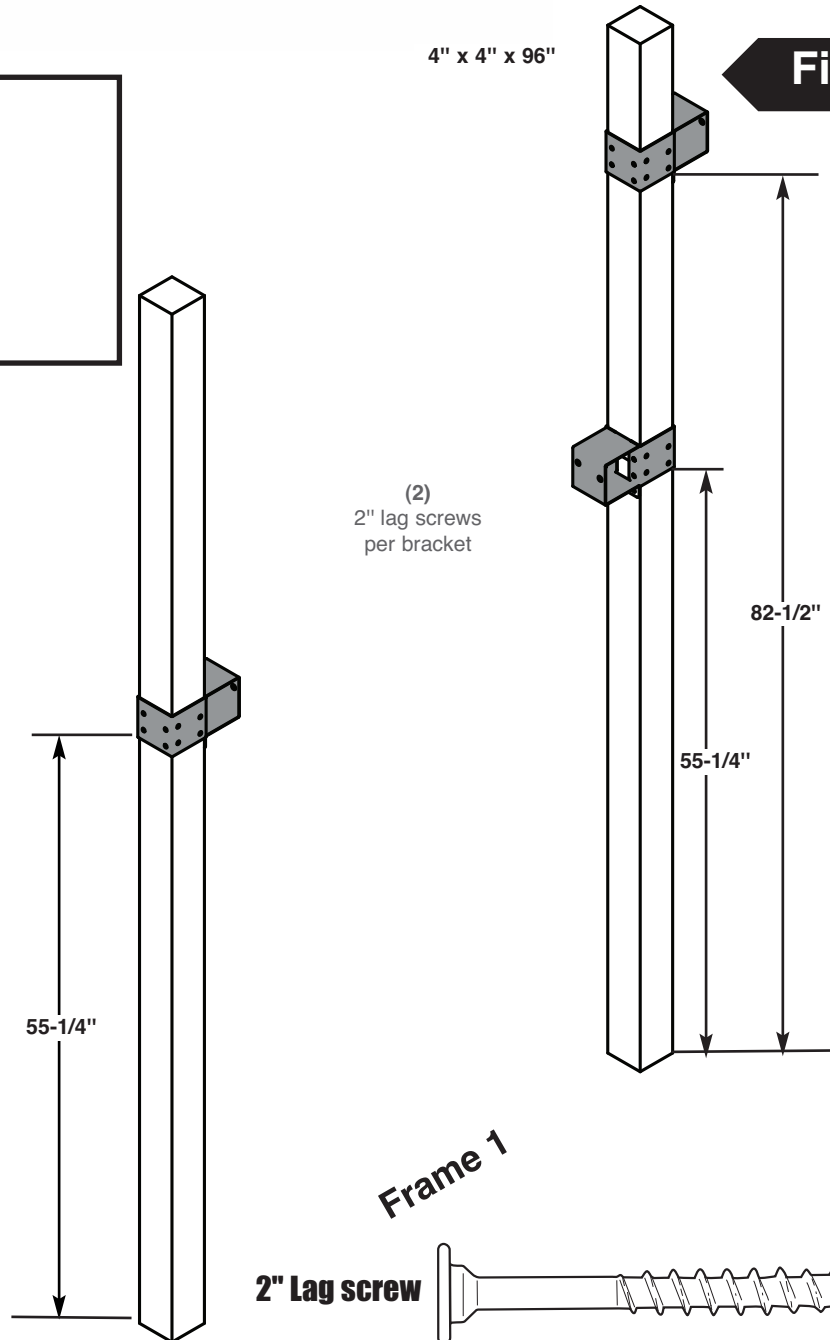
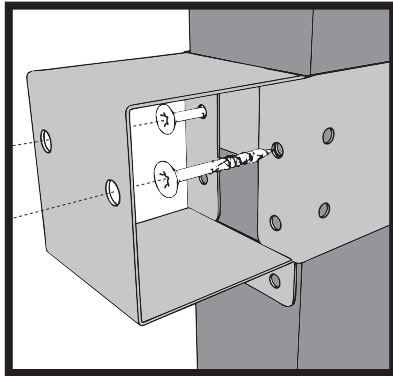
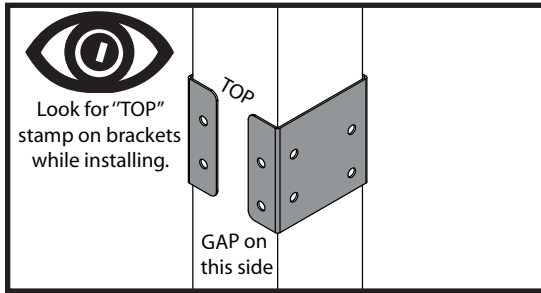
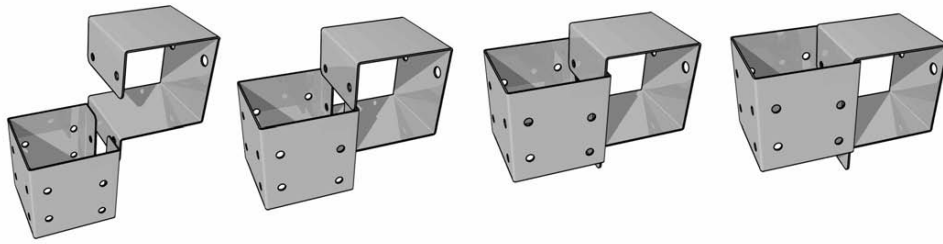


**Brackets Clip Together**

## Introduction to the Bracket system

1. **ALWAYS** Use 2" lag screws on all brackets.
2. Brackets "clip" to each other. **NEVER** position in a non-interlocking position.

# PROJECT 514

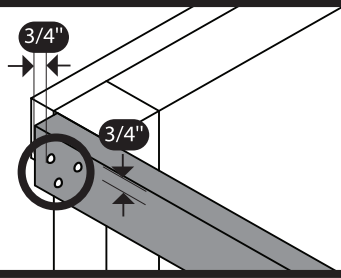


## **A. Frame 1 Construction**

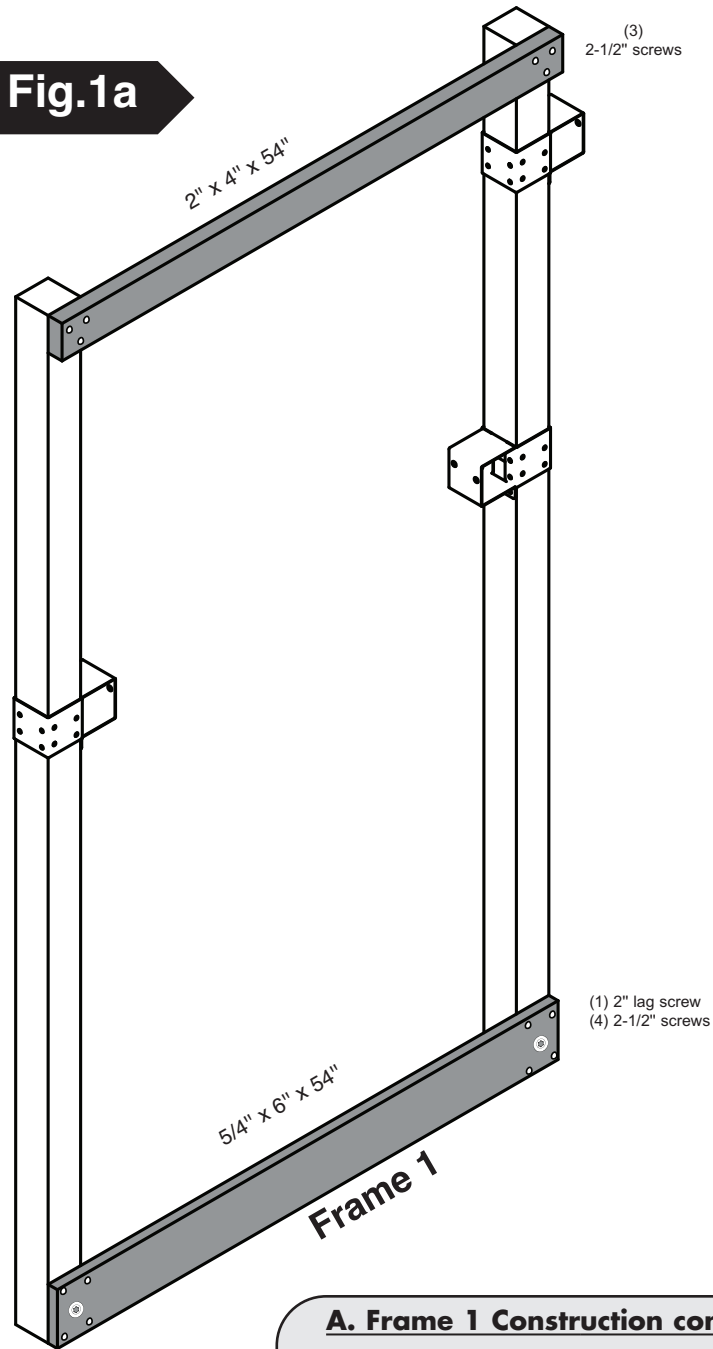
1. Measure and position brackets on 4" x 4" as shown in **(Fig.1)**.

**Note:** Secure Shelf Lock with **(2) Lag Screws only** at this time.

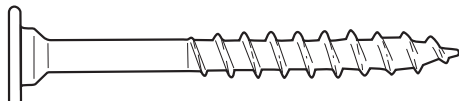
**•WARNING•**  
 Avoid splitting your  
 lumber by offsetting  
 your screws at least  
 3/4" from edge.



**Fig.1a**



**2" Lag screw**



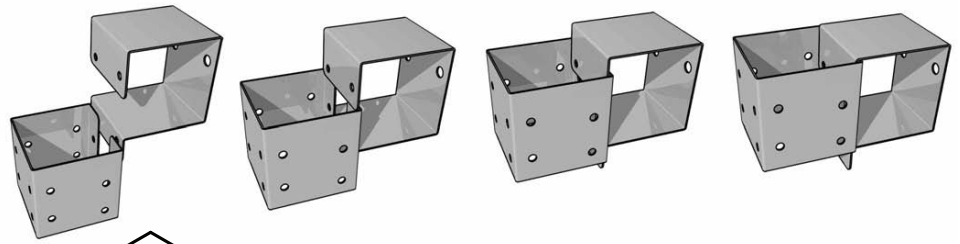
**2-1/2" screw**



**A. Frame 1 Construction cont.**

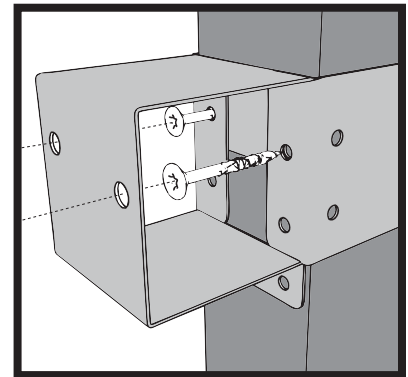
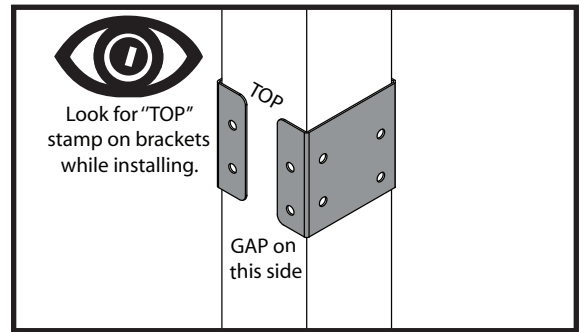
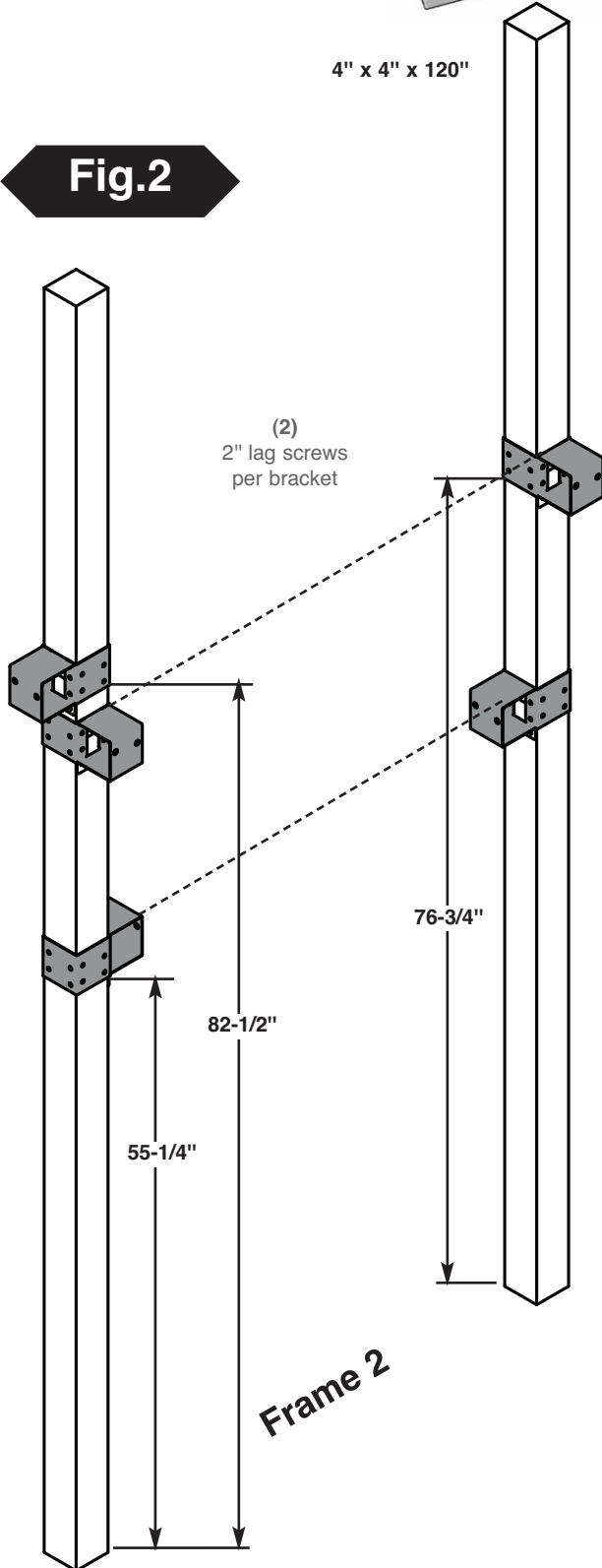
**2.** Attach upper 2" x 4" and lower 5/4" boards as shown in **(Fig. 1a)**

# PROJECT 514

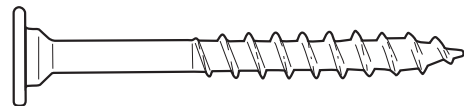


4" x 4" x 120"

**Fig.2**



**2" Lag screw**



## **B. Frame 2 Construction**

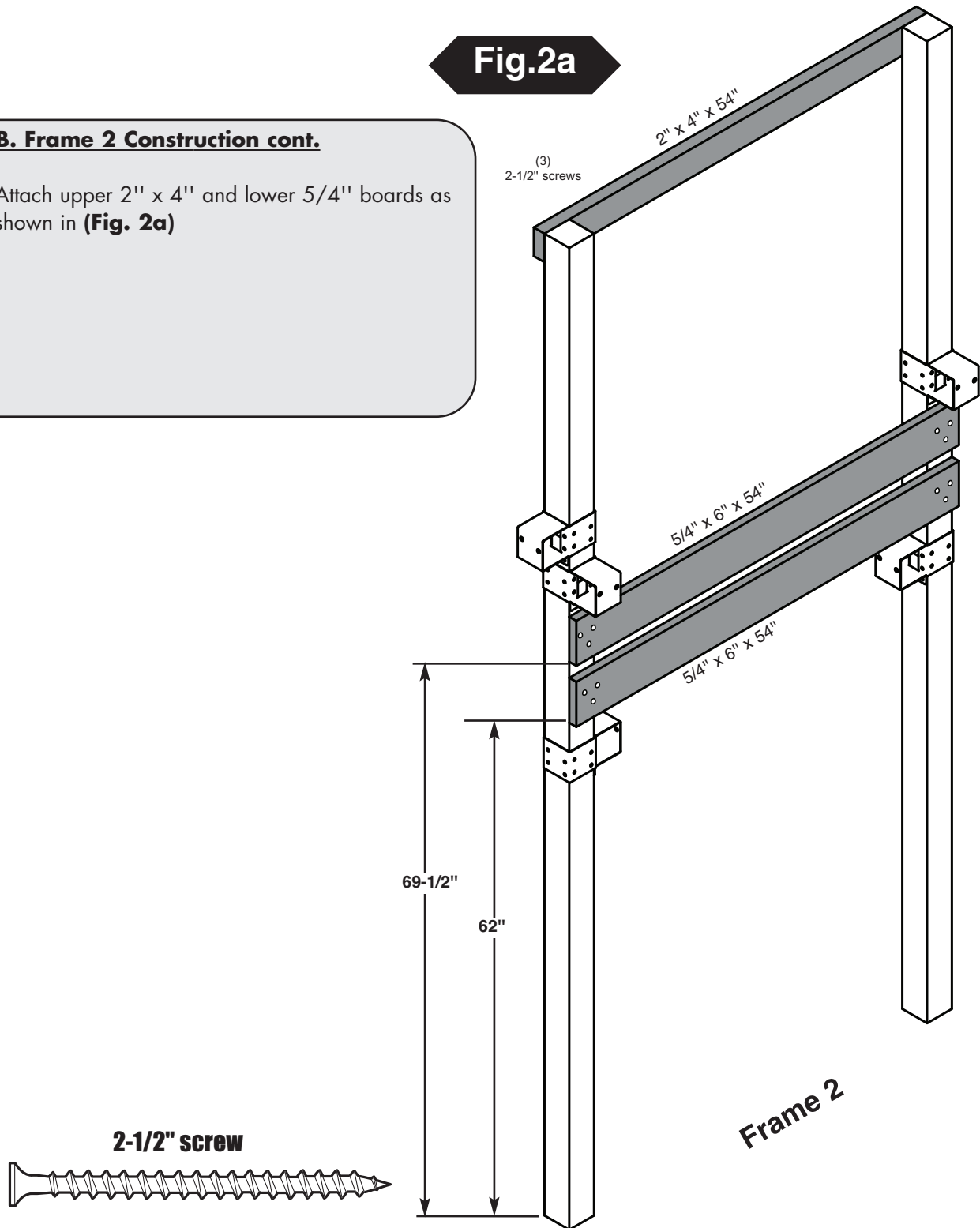
1. Measure and position brackets on 4" x 4" as shown in **(Fig.2)**.

**Note:** Secure Shelf Lock with **(2) Lag Screws only** at this time.

## Fig.2a

### B. Frame 2 Construction cont.

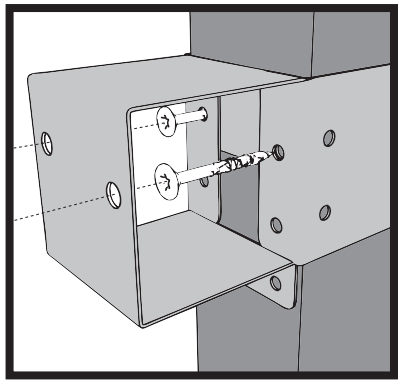
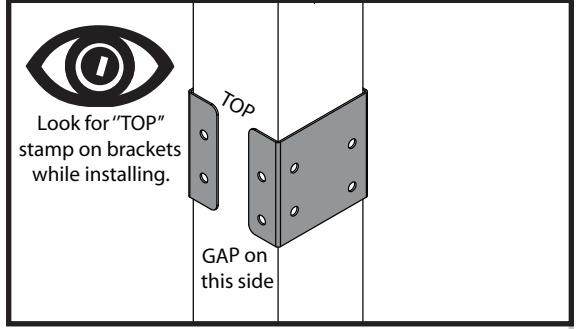
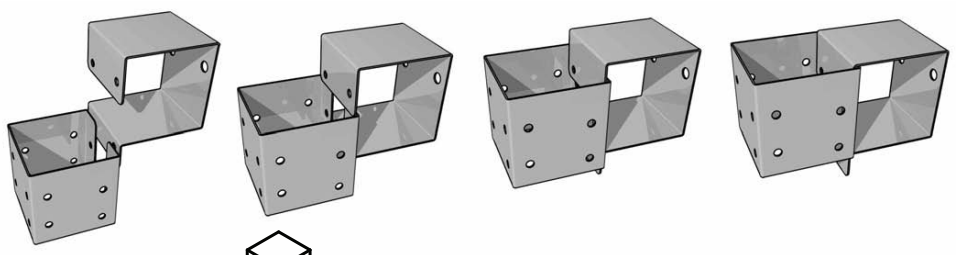
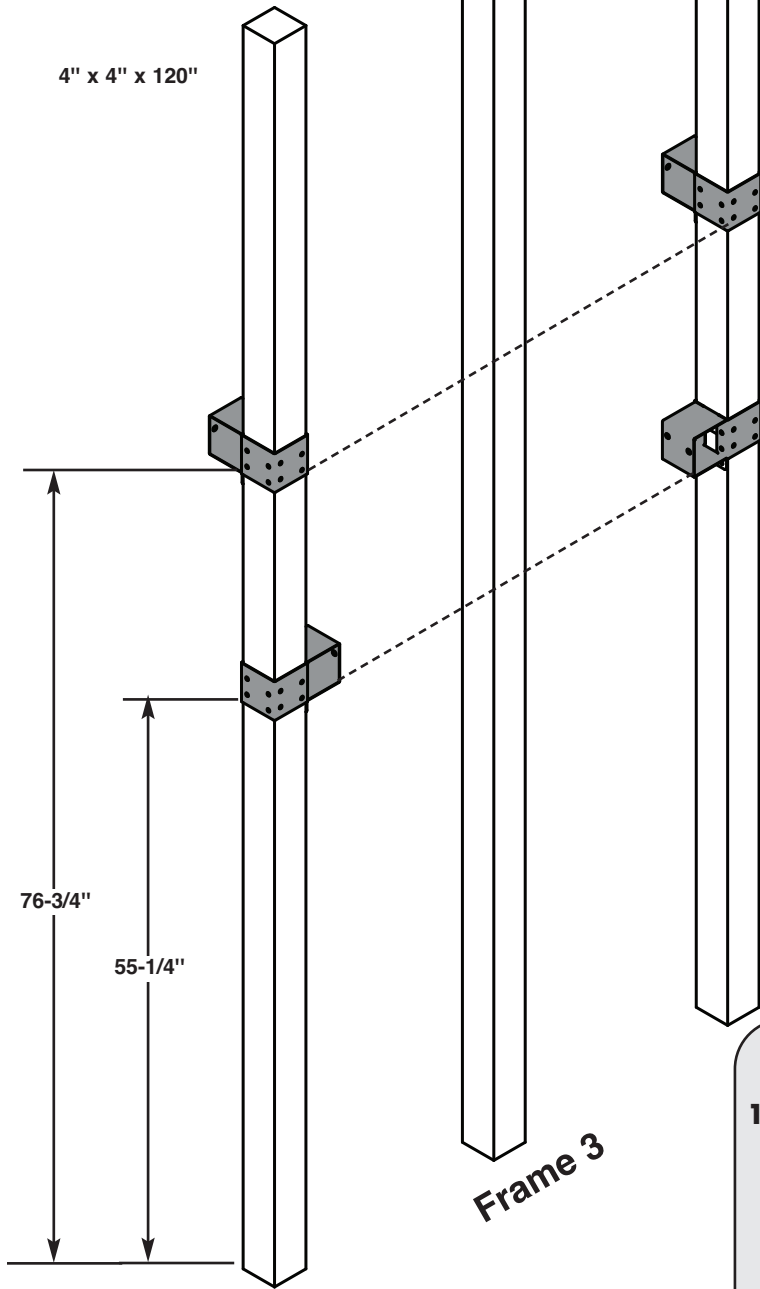
2. Attach upper 2" x 4" and lower 5/4" boards as shown in (Fig. 2a)



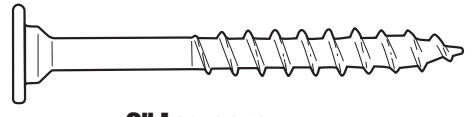
# PROJECT 514

**Fig.3**

4" x 4" x 120"



(2)  
2" lag screws  
per bracket



**2" Lag screw**

### C. Frame 3 Construction

1. Measure and position brackets on 4" x 4" as shown in **(Fig.3)**.

**Note:** Secure Shelf Lock with **(2) Lag Screws only** at this time.

**Fig.3a**

(3)  
2-1/2" screws

2" x 4" x 54"

2" x 4" x 54"

5/4" x 6" x 54"

**Frame 3**

80-1/2"

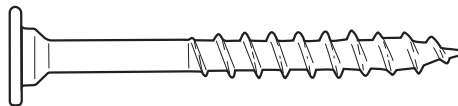
(1) 2" lag screw  
(4) 2-1/2" screws

29-1/2"

**C. Frame 3 Construction cont.**

2. Attach upper 2" x 4" and lower 5/4" boards as shown in **(Fig. 3a)**

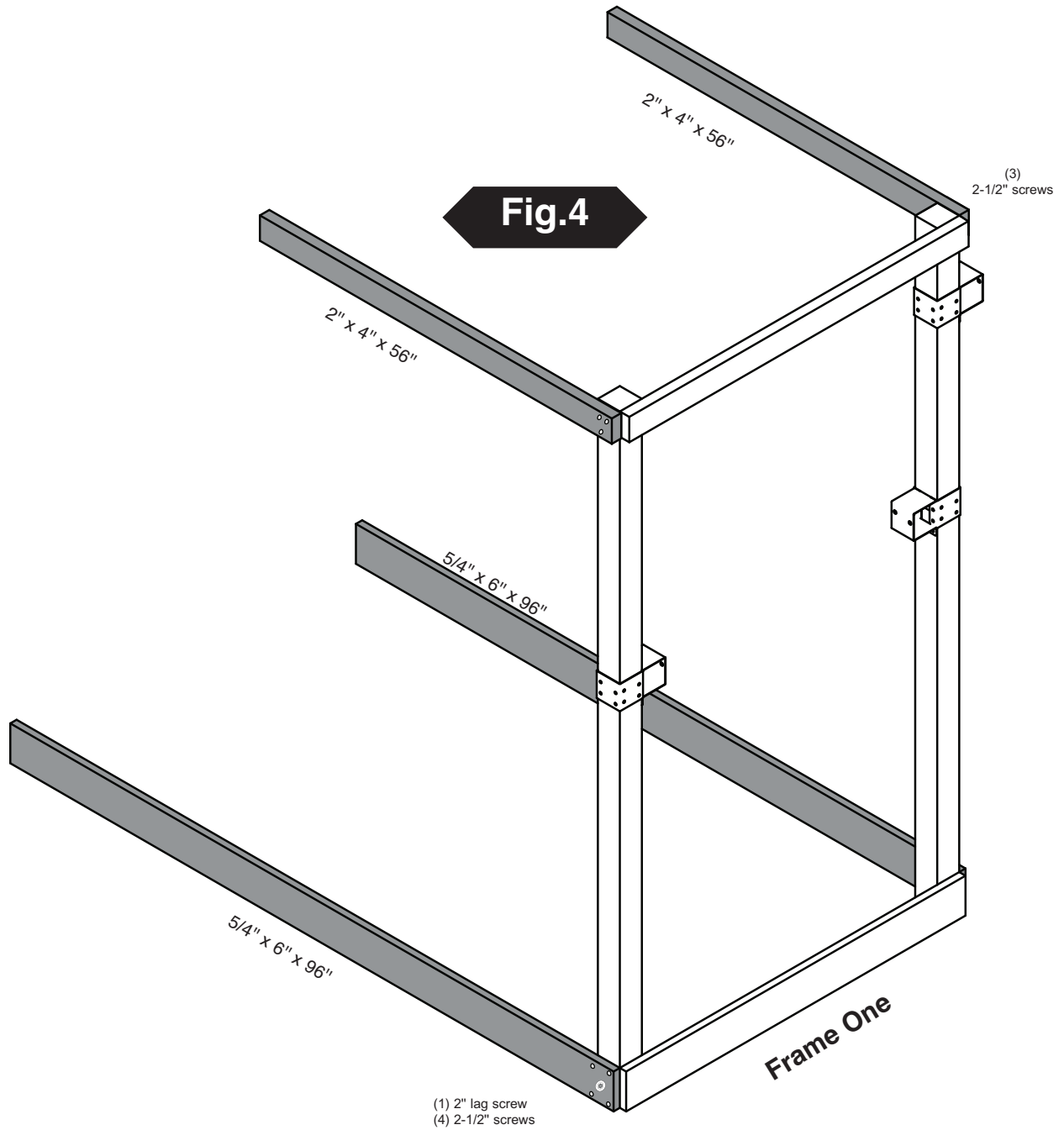
**2" Lag screw**



**2-1/2" screw**



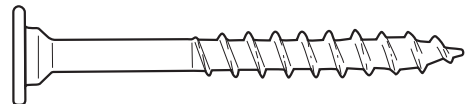
# PROJECT 514



## D. Frame Construction

1. Install 2" x 4" and 5/4" boards as shown above.

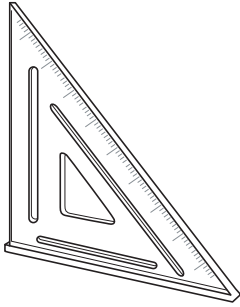
**2" Lag screw**



**2-1/2" screw**



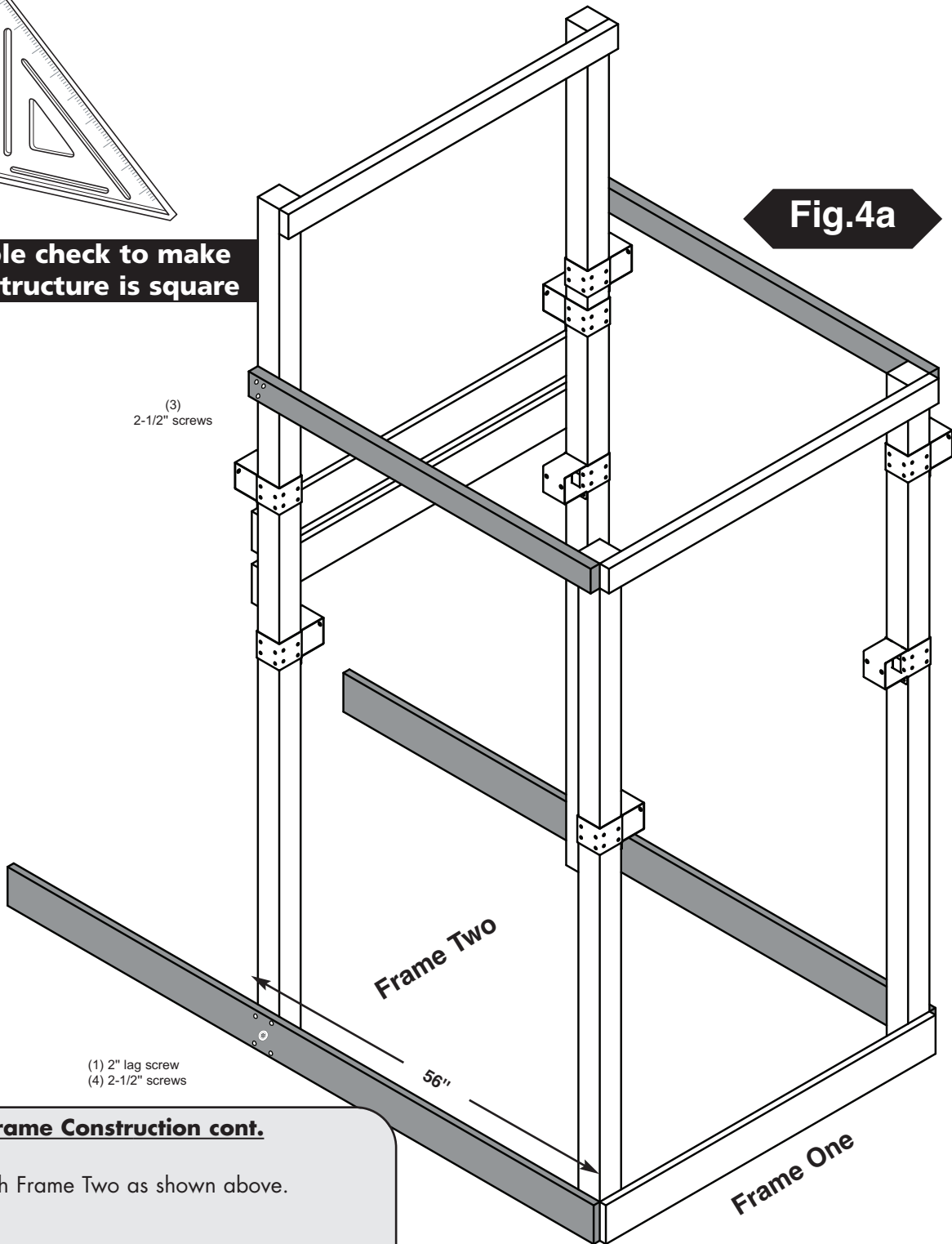




**Fig.4a**

**Double check to make sure structure is square**

(3)  
2-1/2" screws



(1) 2" lag screw  
(4) 2-1/2" screws

Frame Two

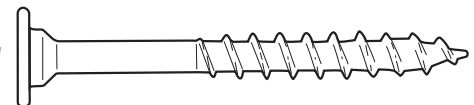
Frame One

56"

### **D. Frame Construction cont.**

1. Attach Frame Two as shown above.

**2" Lag screw**

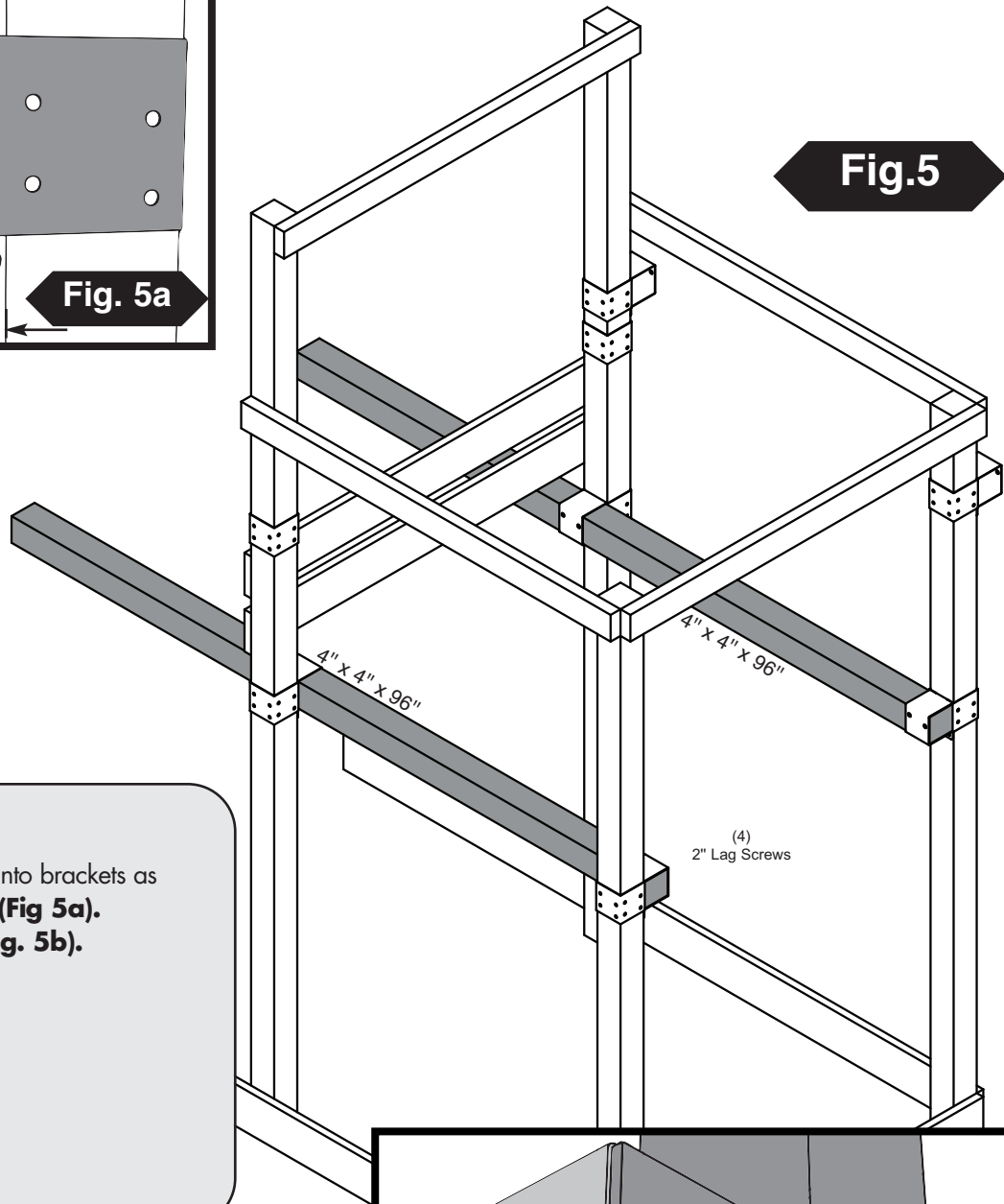
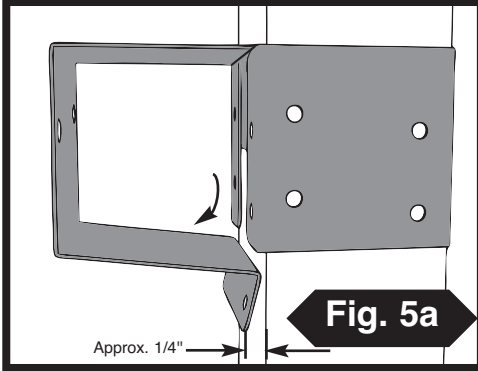


**2-1/2" screw**



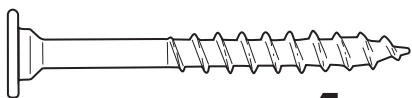
# PROJECT 514

Tip: Flex brackets to make installation of 4" x 4" easier

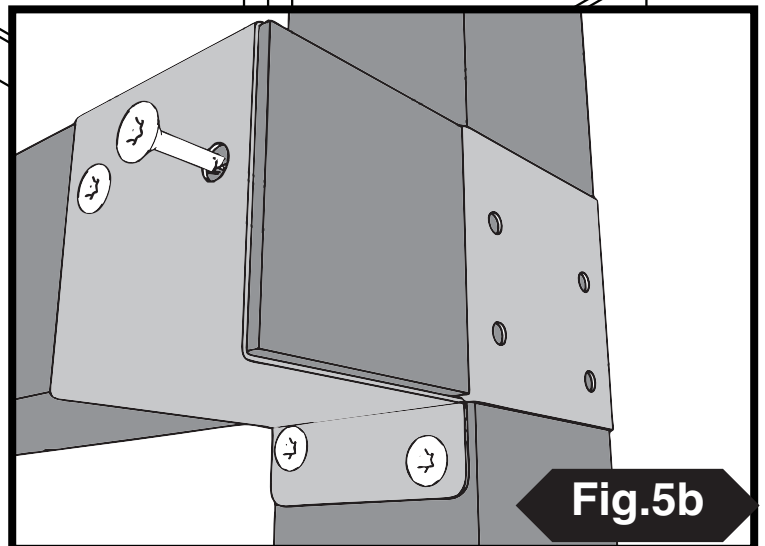


## F. Install 4x4s

1. Work (2) 4" x 4" into brackets as shown in **(Fig. 5)**, **(Fig 5a)**.
2. Secure brackets **(Fig. 5b)**.

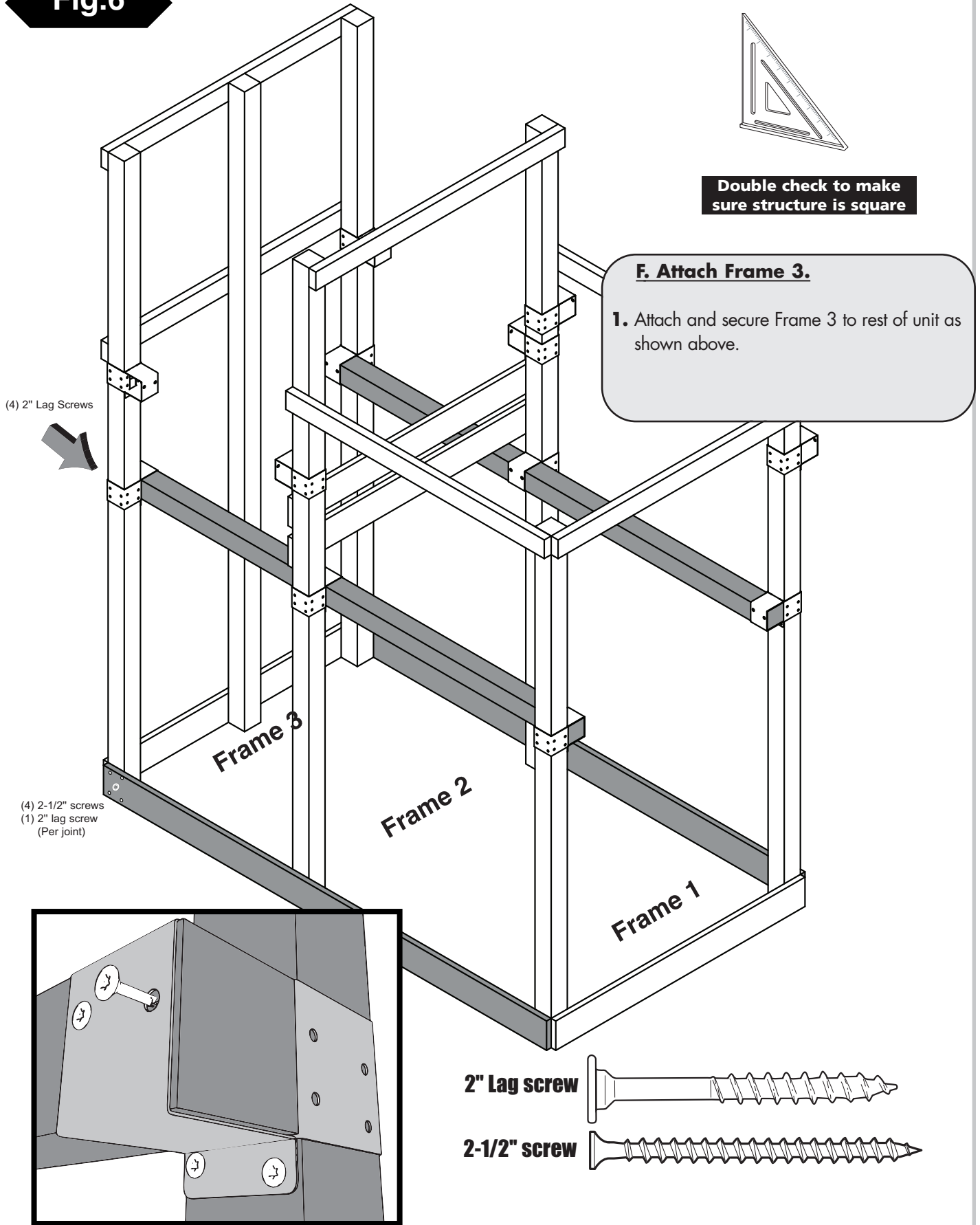


**2" Lag screw x 4**

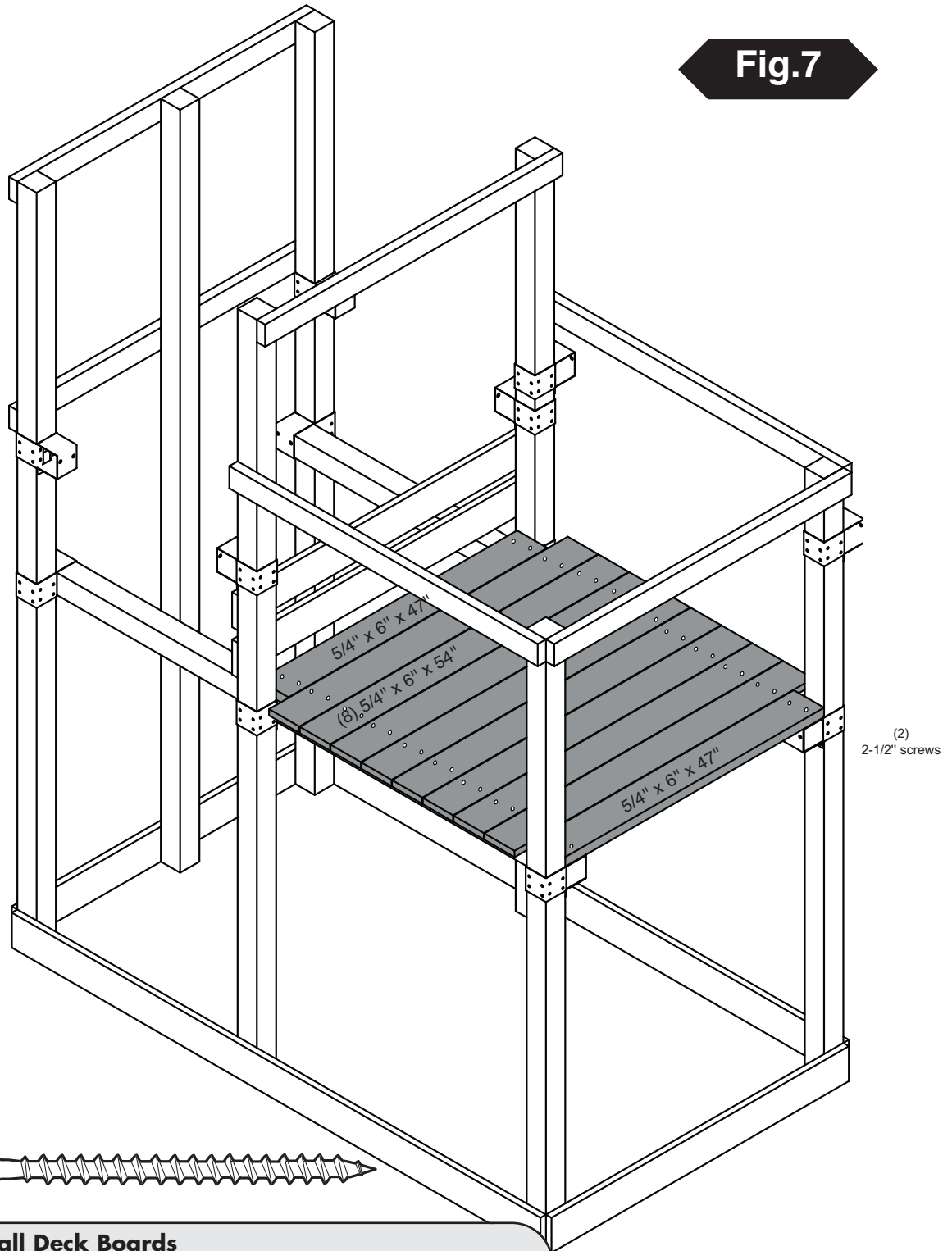


**Fig. 5b**

## Fig.6



**Fig.7**



**2-1/2" screw**

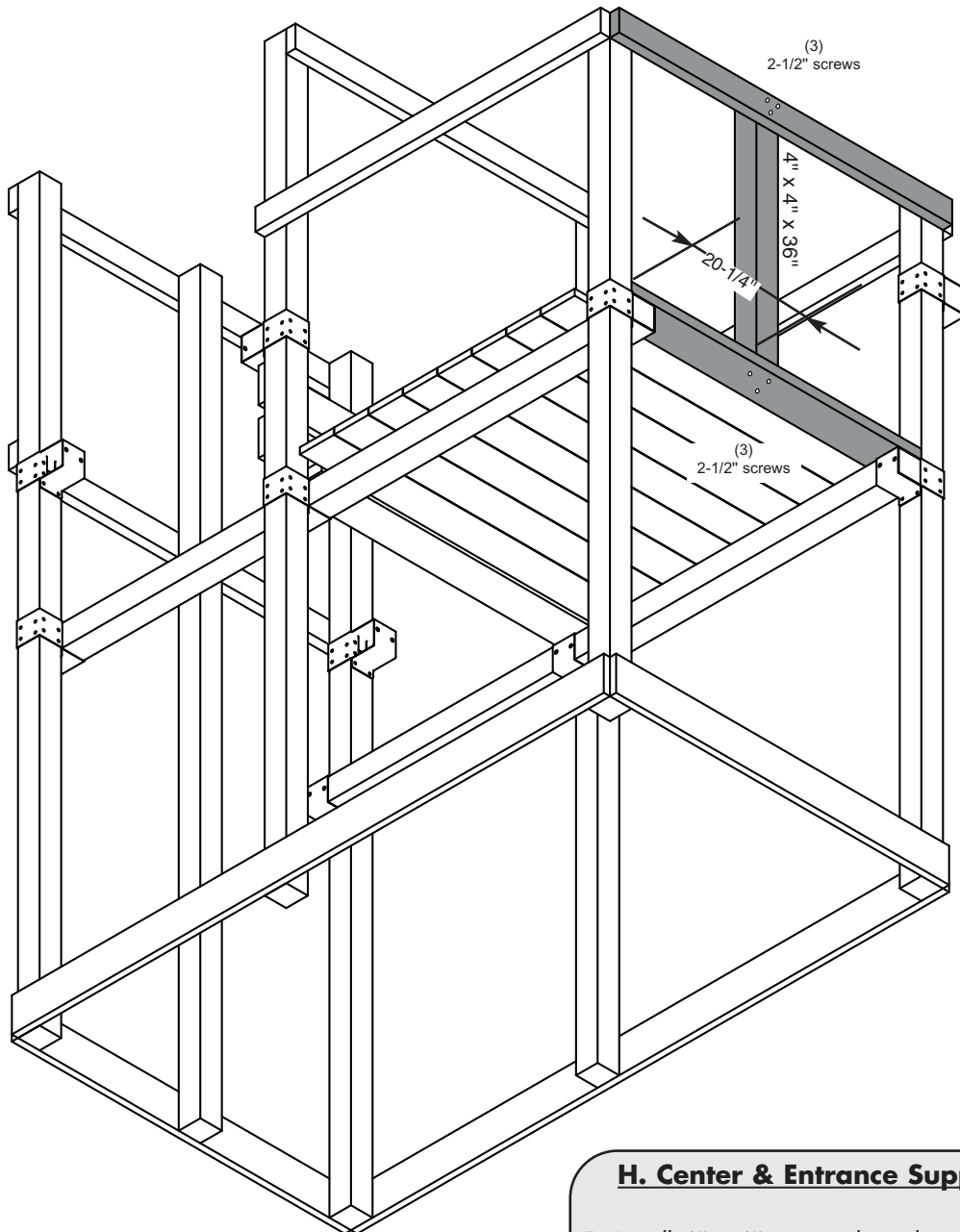


### **G. Install Deck Boards**

- 1.** Install 5/4" deck boards to structure as shown (**Fig. 7**).
- 2.** Use two 2-1/2" screws at each end of deck boards.

**Note:** On End Boards, avoid screwing into Shelf Brackets by placing screws behind Shelf Bracket location.

**Fig.7a**



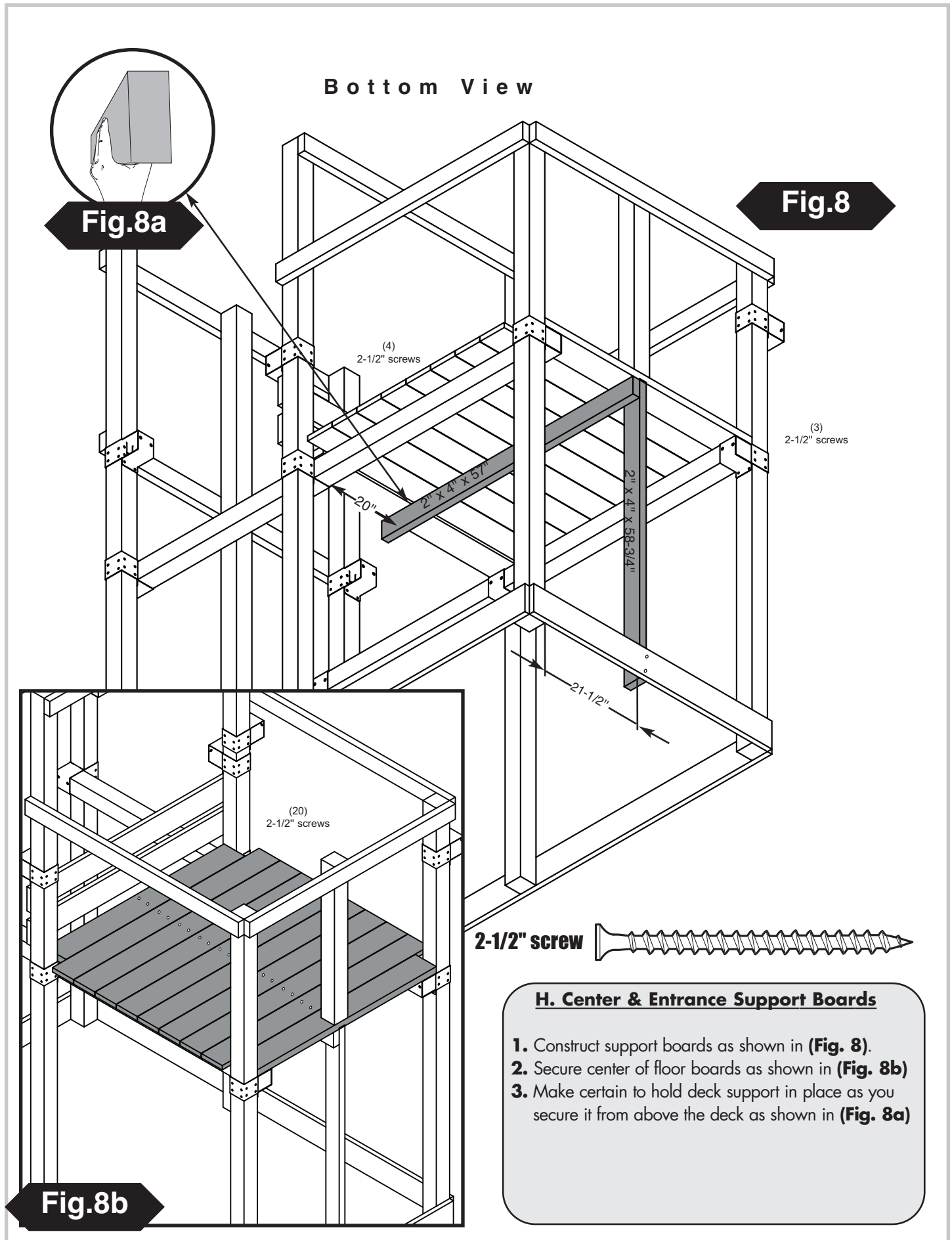
**2-1/2" screw**

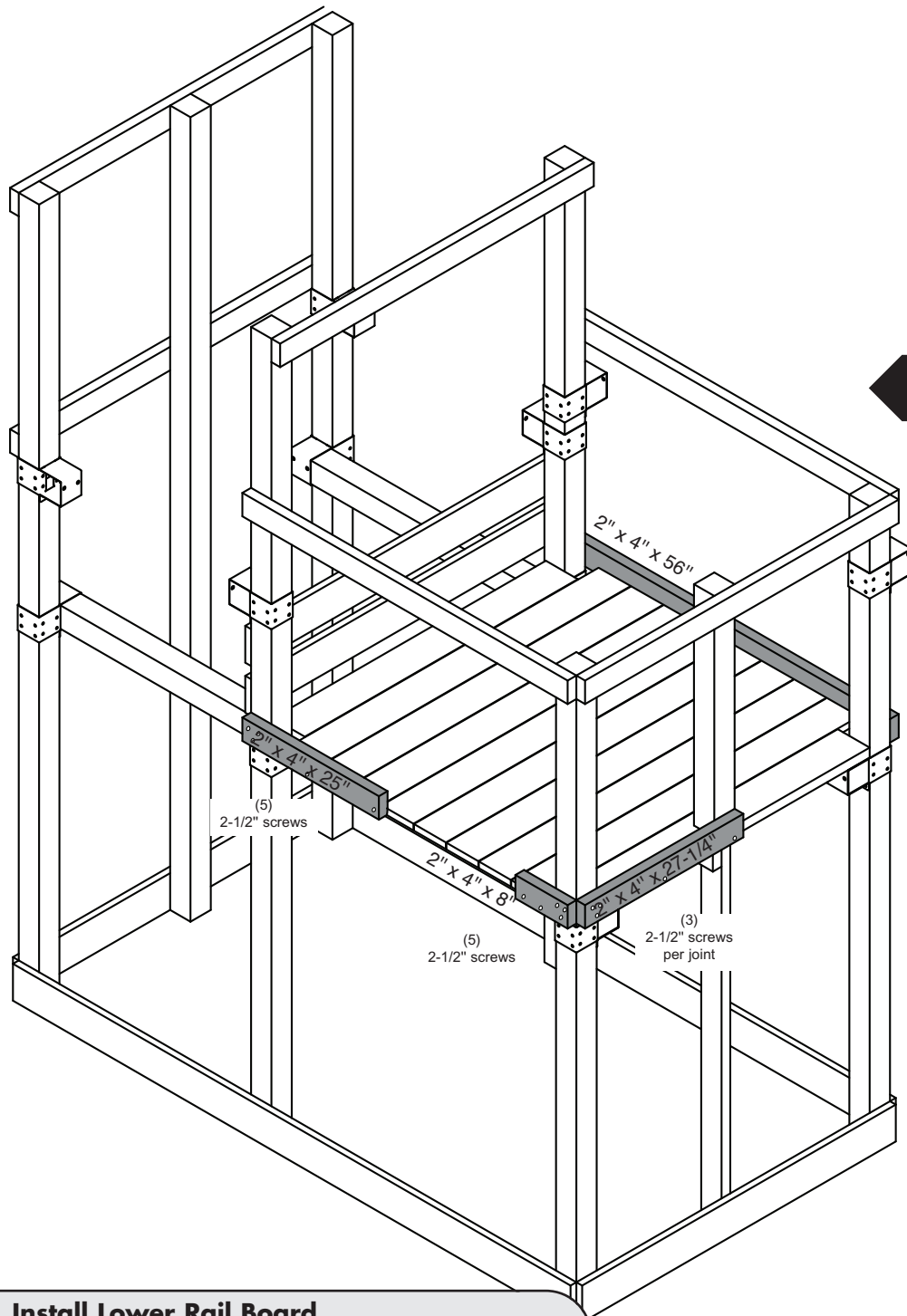


### **H. Center & Entrance Support Boards**

- 1.** Install 4" x 4" support boards as shown in **(Fig. 7a)**.
- 2.** Secure bottom of 4" x 4" as shown in **(Fig 7a)**

# PROJECT 514





**Fig.9**

(3)  
2-1/2" screws  
per joint

(5)  
2-1/2" screws

(5)  
2-1/2" screws

(3)  
2-1/2" screws  
per joint

## I. Install Lower Rail Board

1. Install lower 2" x 4" rail board as shown in (Fig 9). Flush with the sides of 4" x 4" deck supports.

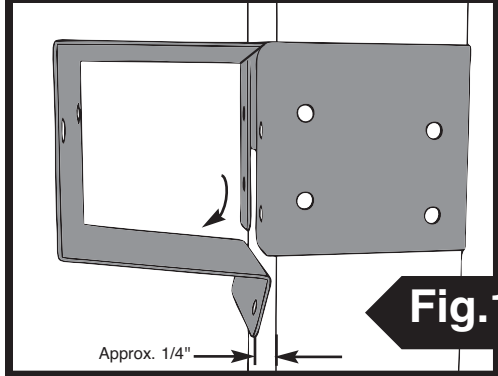
**NOTE:** The bottom screw in the 2" x 4" board should secure into the side of the 5/4" x 6" deck board.

**2-1/2" screw**

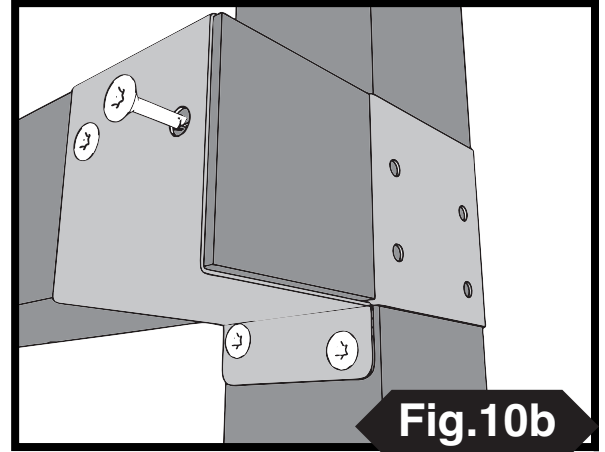


# PROJECT 514

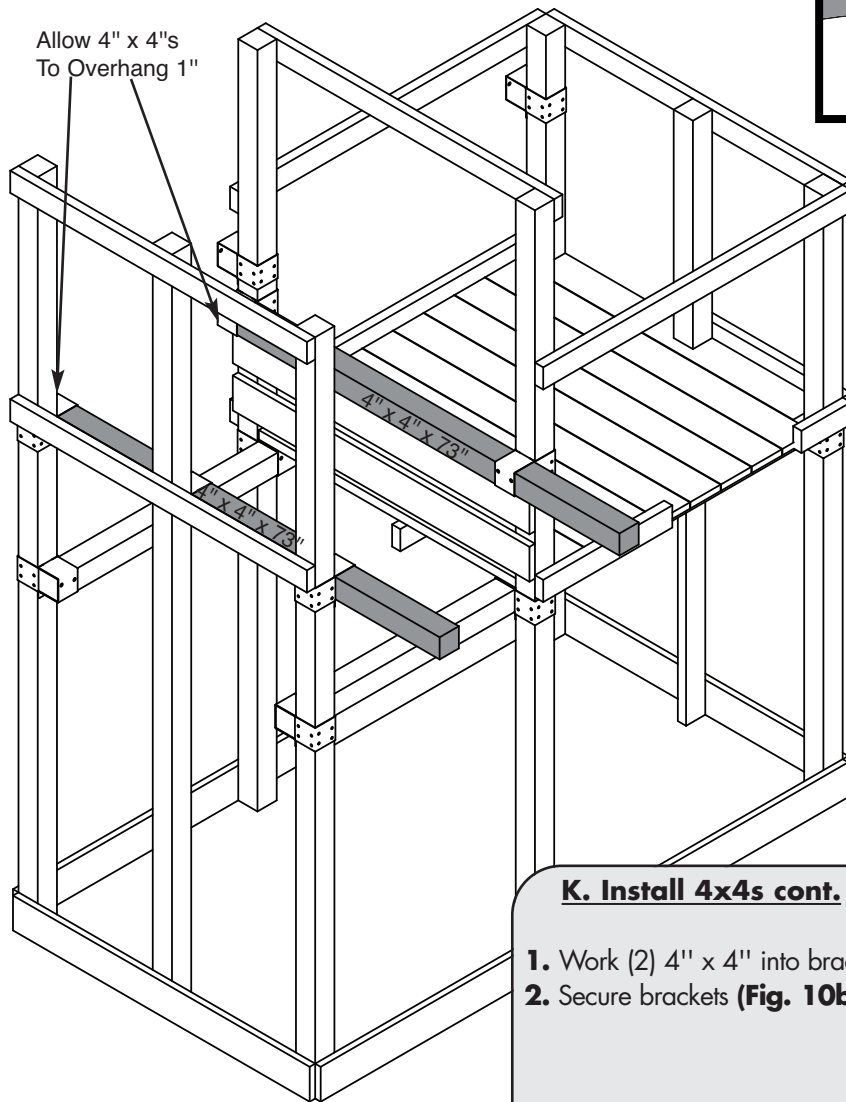
Tip: Flex brackets to make installation of 4" x 4" easier



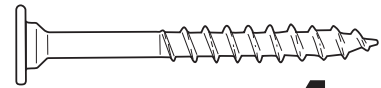
**Fig.10a**



**Fig.10b**



**Fig.10**



**2" Lag screw X 4**

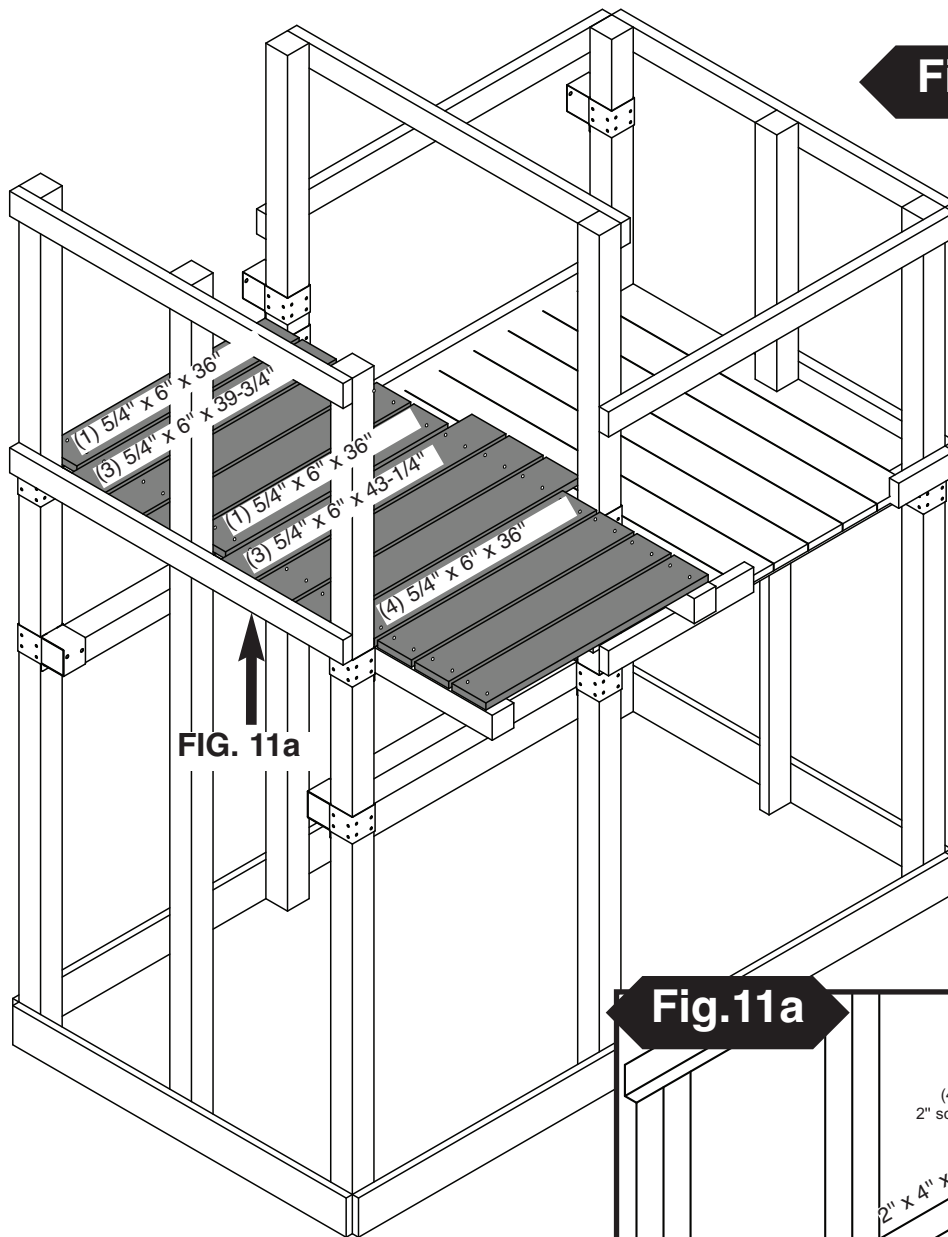
## **K. Install 4x4s cont.**

- 1. Work (2) 4" x 4" into brackets as shown in (Fig. 10a), (Fig 10).**
- 2. Secure brackets (Fig. 10b).**



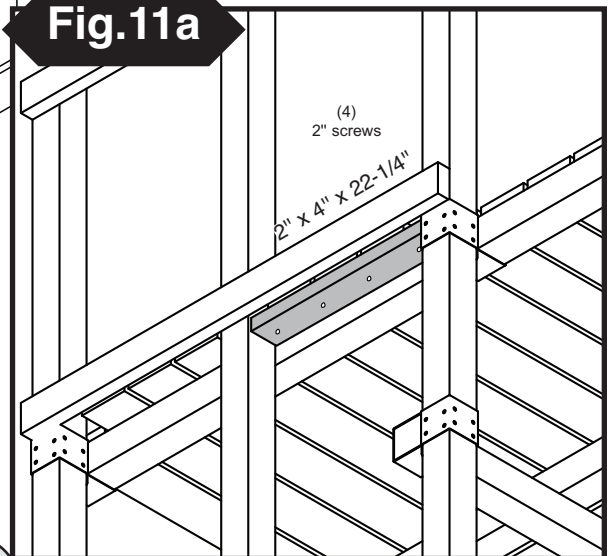
**Fig.11**

(2)  
2-1/2" Deck Screws  
(2 per joint)



**FIG. 11a**

**Fig.11a**

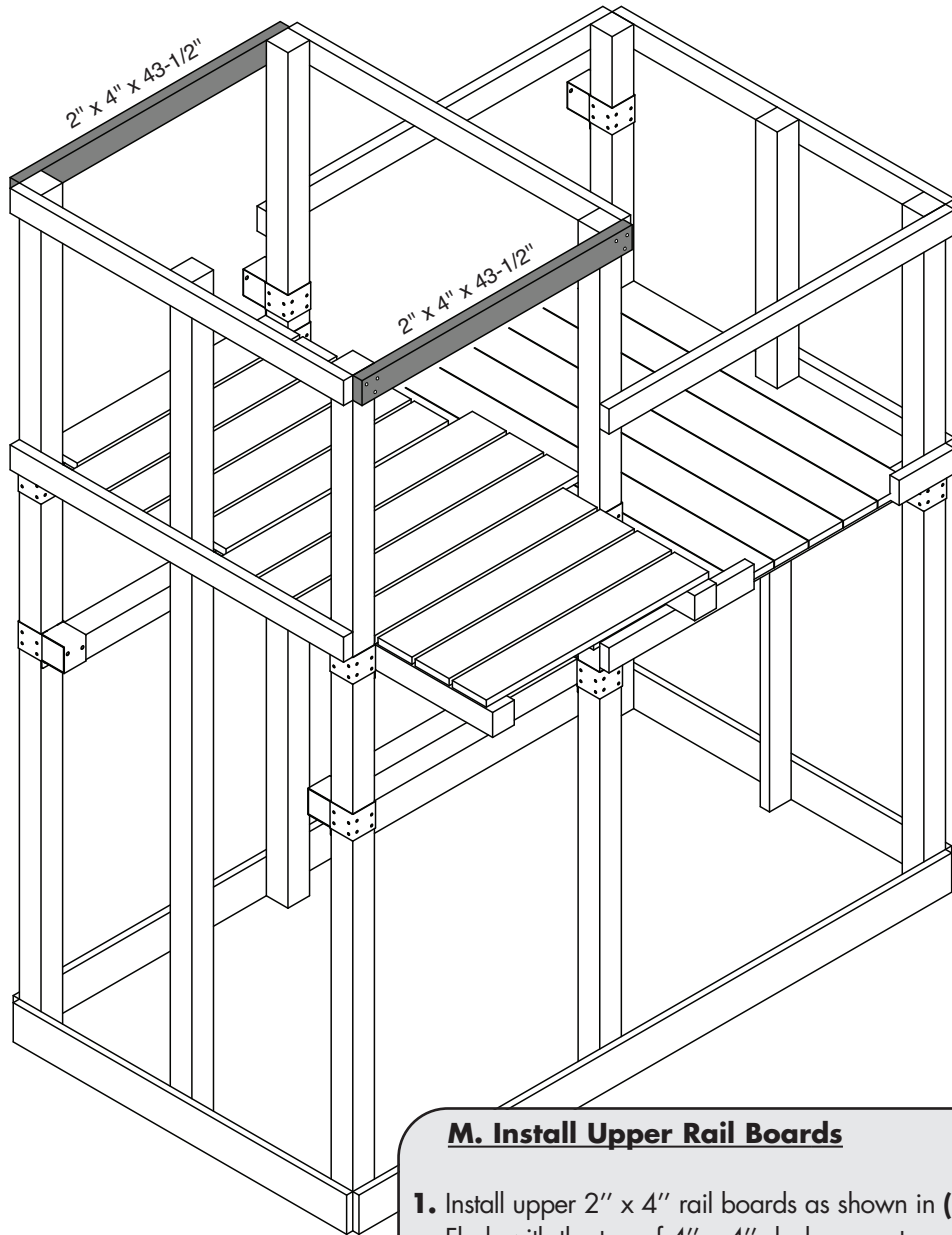


### **L. Install Deck Boards**

- 1.** Install 5/4" deck boards to structure as shown (**Fig. 11**).
- 2.** Use two 2-1/2" screws at each end of deck boards. Where shelf bracket blocks screw path, center board and place one screw on either side.
- 3.** Attach under deck support board as shown in (**Fig. 11a**).

**Fig.12**

(2)  
2-1/2" Screws  
(2 per joint)

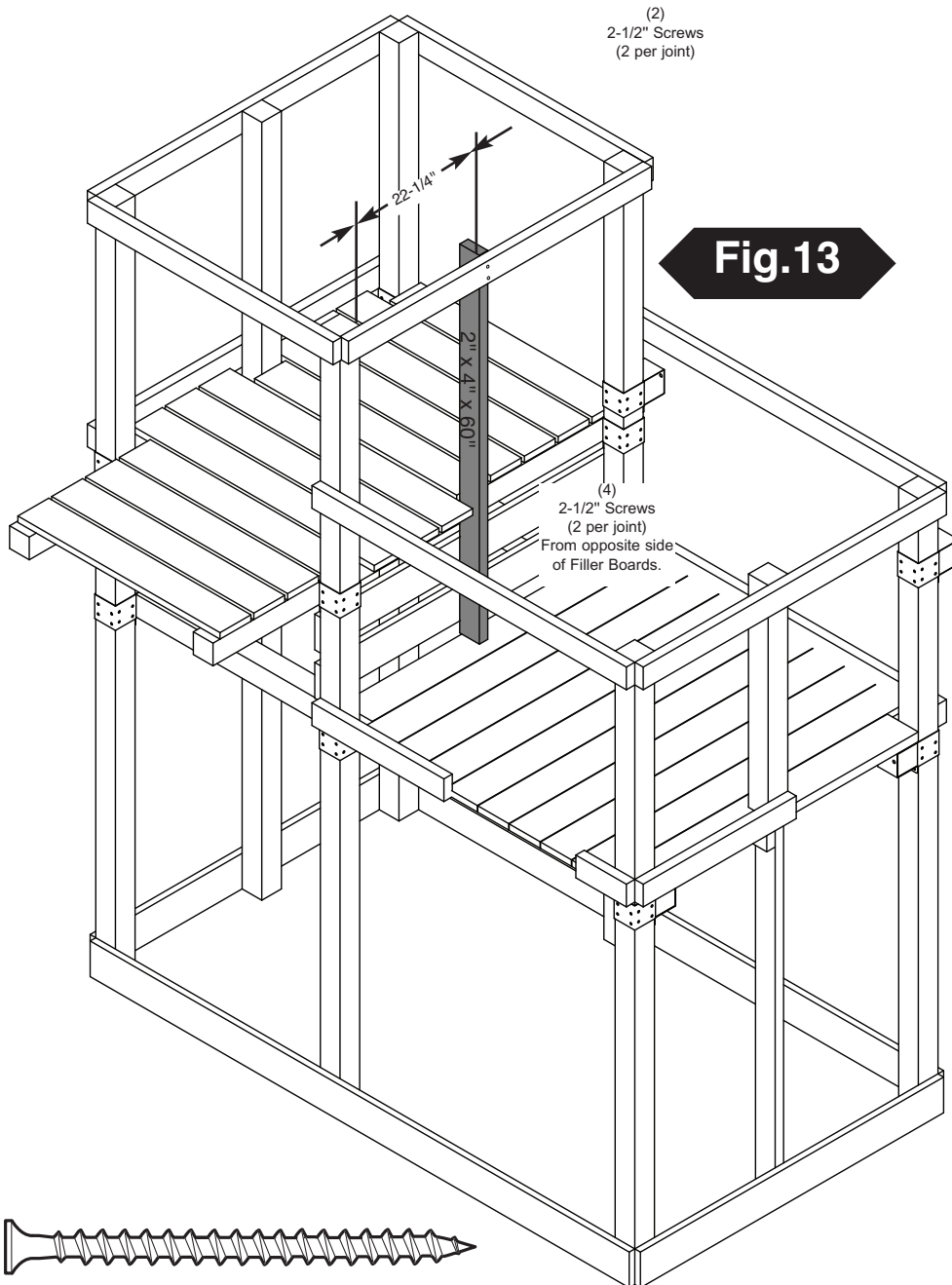


**2-1/2" screw**



### **M. Install Upper Rail Boards**

- 1.** Install upper 2" x 4" rail boards as shown in **(Fig 12)**. Flush with the top of 4" x 4" deck supports.

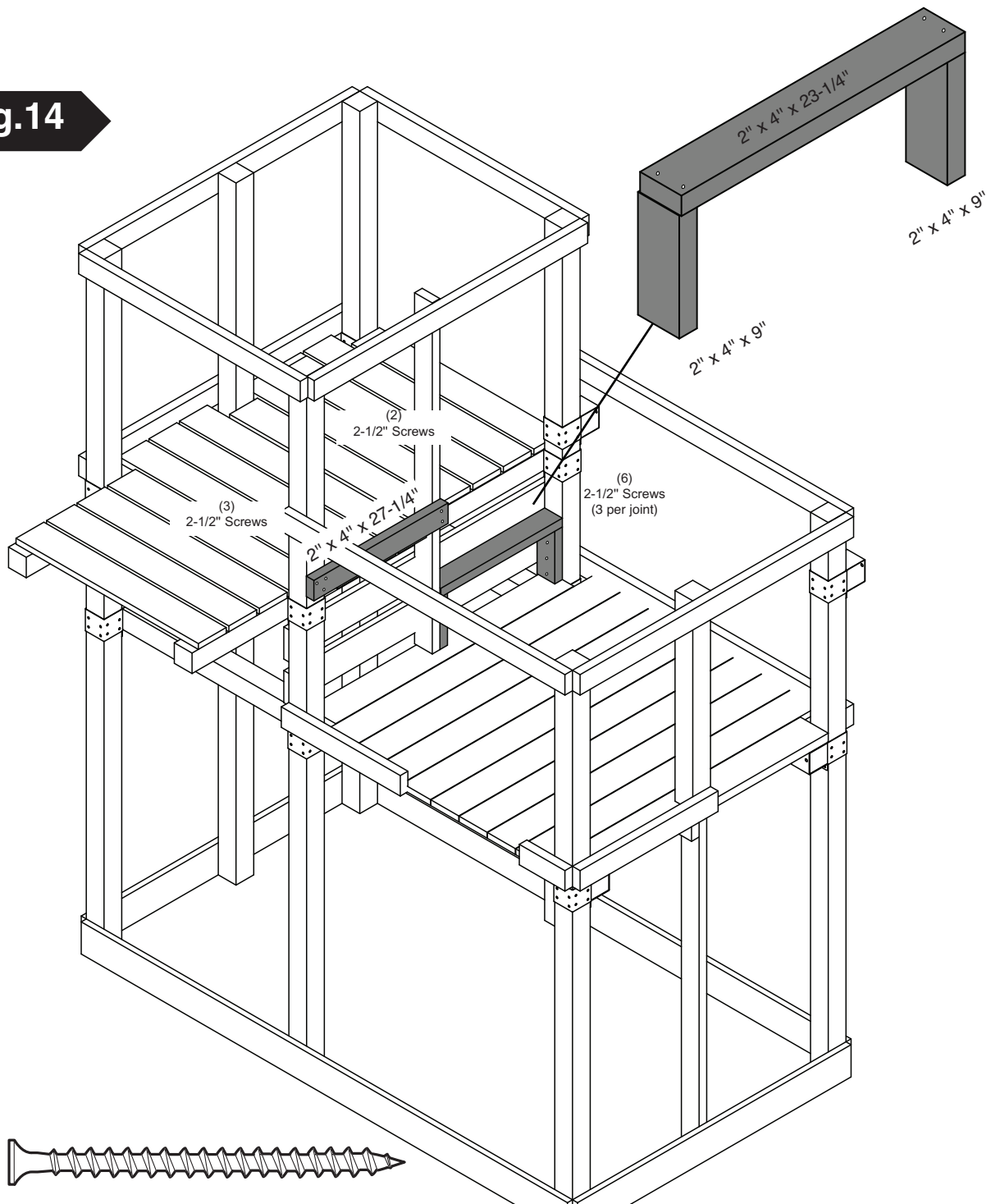


## **N. Install supports cont.**

1. Install 2" x 4" as shown in **(Fig 13)**

# PROJECT 514

**Fig.14**



**2-1/2" screw**

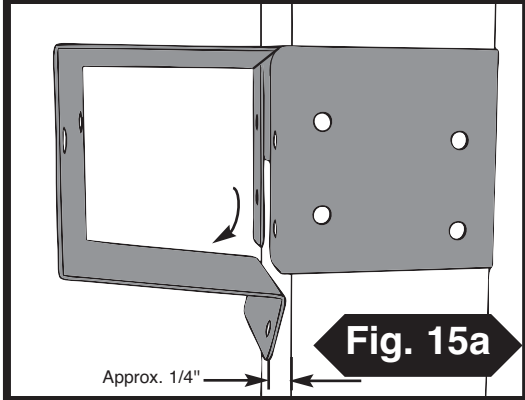


**N. Install supports cont.**

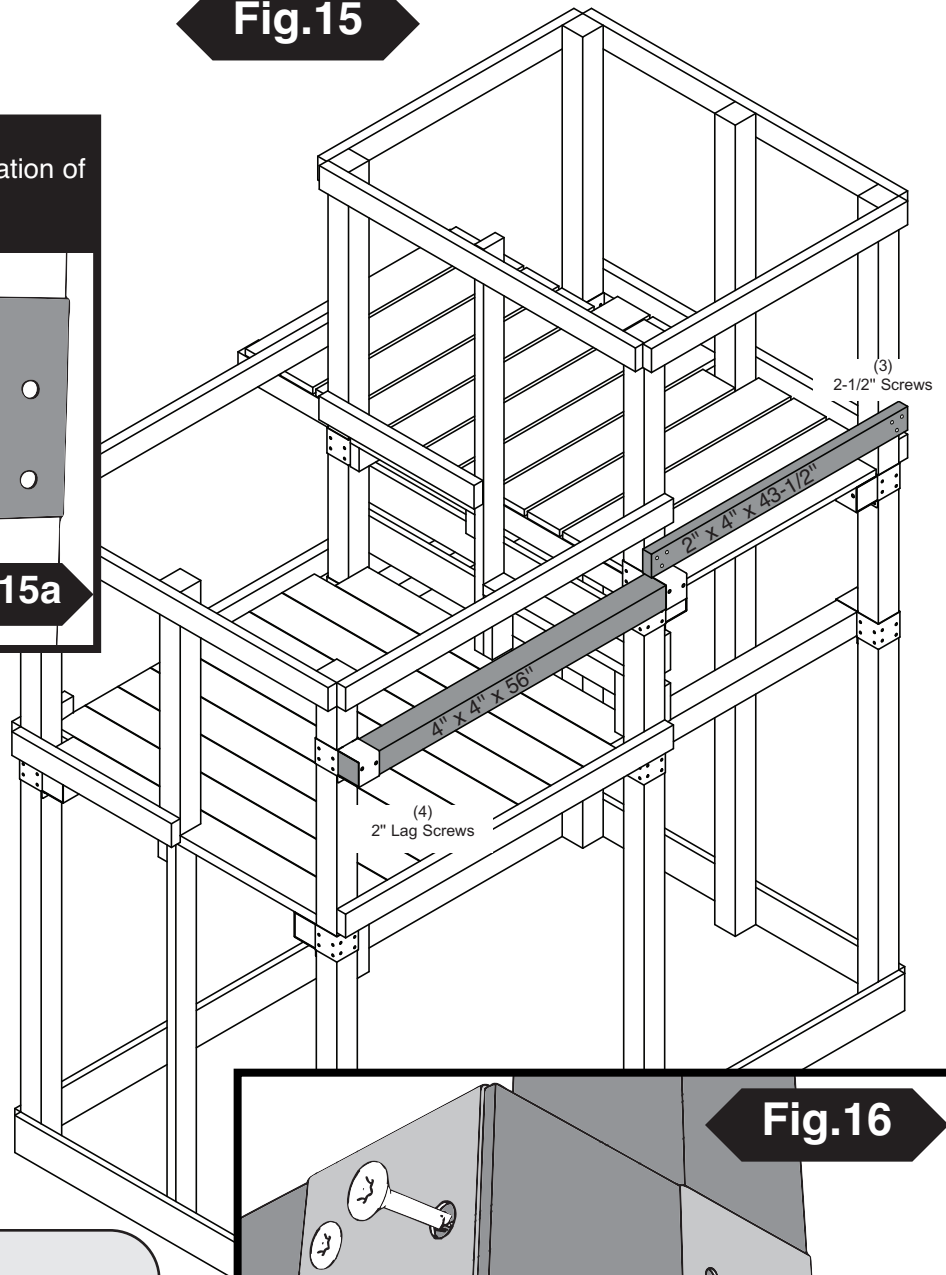
1. Install 2" x 4" flush with top of Shelf-Loc Bracket as shown in **(Fig 14)**
2. Install step as shown in **(Fig 14)**.

**Fig.15**

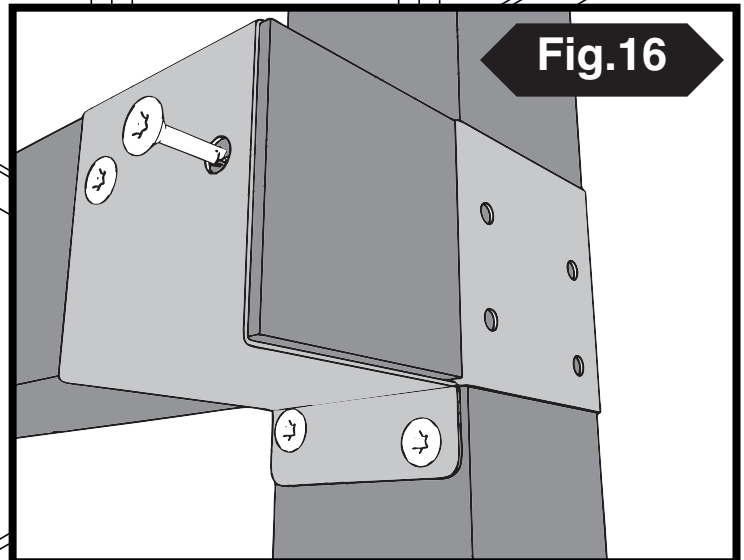
Tip: Flex brackets to make installation of 4" x 4" easier



**Fig. 15a**

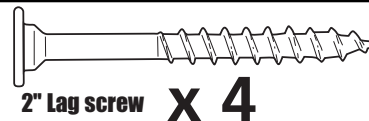


**Fig.16**



**O. Install accessory 4x4**

1. Work (1) 4" x 4" into brackets as shown in **(Fig. 15a), (Fig 15)**.
2. Secure brackets **(Fig. 16)**.
3. Install 2" x 4" x 43" as shown in **(Fig 15)**.

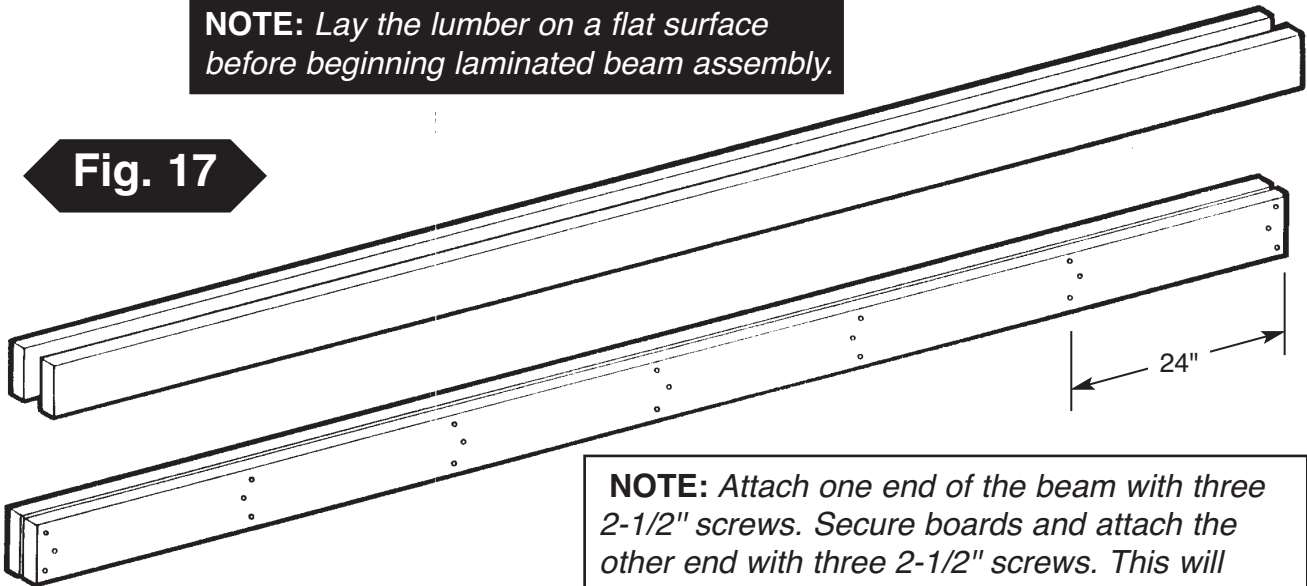


2" Lag screw **X 4**

## Optional Laminated Beam

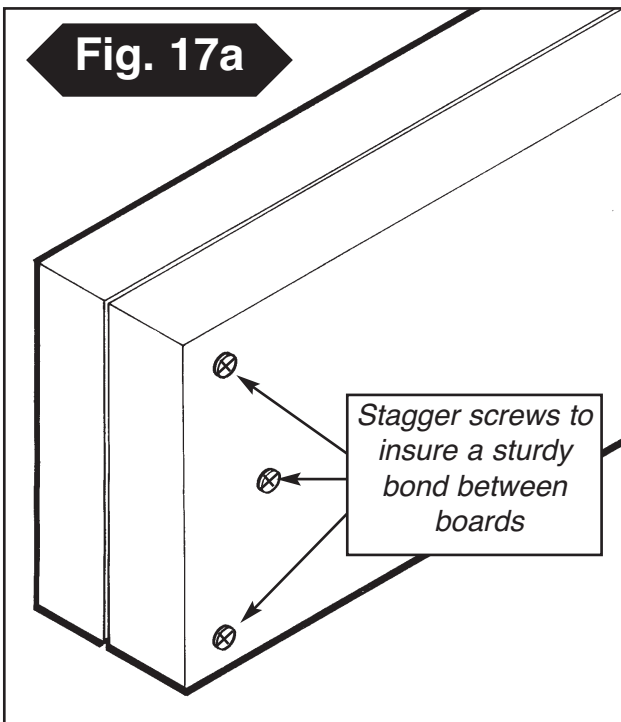
**NOTE:** Lay the lumber on a flat surface before beginning laminated beam assembly.

**Fig. 17**



**NOTE:** Attach one end of the beam with three 2-1/2" screws. Secure boards and attach the other end with three 2-1/2" screws. This will insure that your boards will stay aligned throughout the remainder of the beam assembly.

**Fig. 17a**

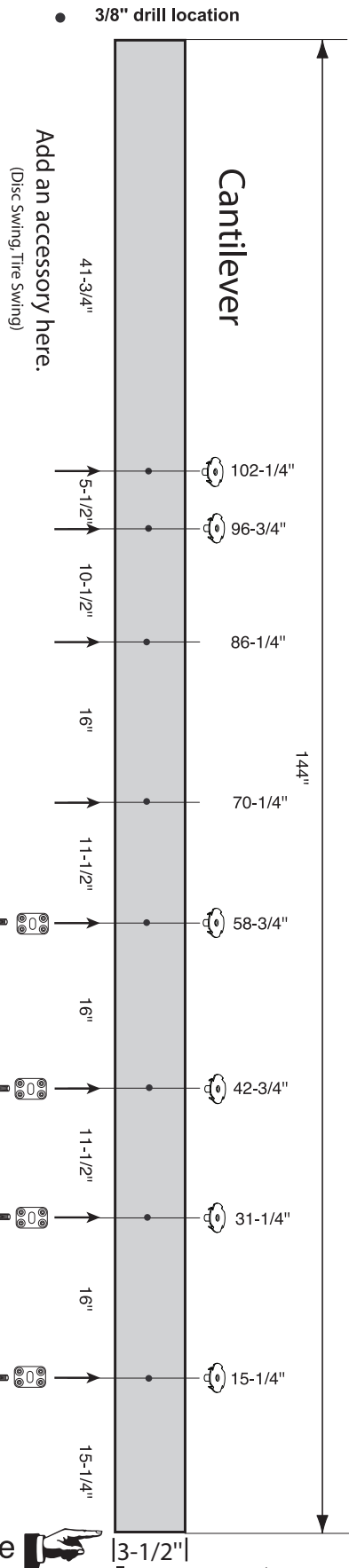


### P. Laminated Beam Instructions

1. If 4" x 6" lumber is not available, you may laminate two 2" x 6" x 144" pieces of lumber together to create the beam.
2. Lay the lumber on a flat surface and align all of the edges. **NOTE:** Make sure each piece of lumber is the same length. If it is not, trim board(s).
3. From the end of each board, measure and place a mark at 24" intervals (**Fig. 17**).
4. Assemble the beam by attaching each end together using three 2-1/2" screws (**Fig. 17a**).

**Note:** Stagger the screws as shown in (**Fig. 17a**) to insure a sturdy bond. Repeat every 24" along the entire length of the beam. When beam is complete, measure, drill holes, and attach beam clamps and nylon bushing swing hangers

**Fig. 18**



Cantilever

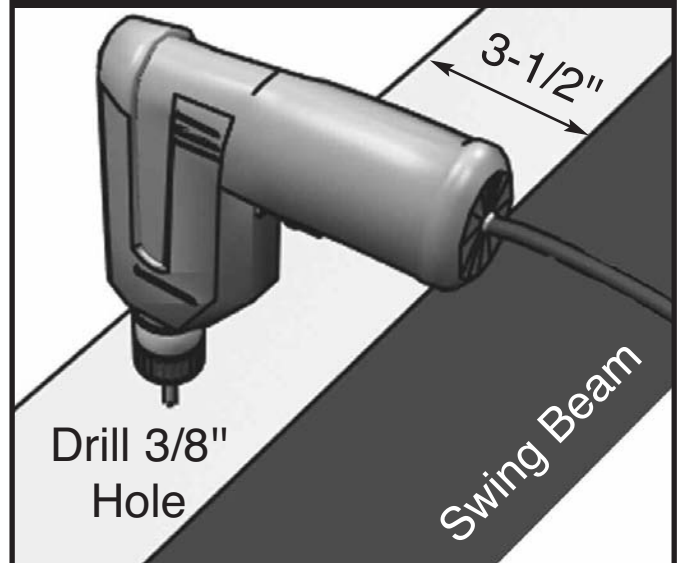
Add an accessory here.  
(Disc Swing, Tire Swing)

**Q. Swing Beam Drill Locations**

1. Use a 3/8" drill bit to drill a 3/8" hole through the beam at each location shown in **(Fig. 18)**
2. Install Swing Hangers onto swing beam at locations shown.

**Note:** Swing Hangers must be installed on same side dimensions were originally marked.

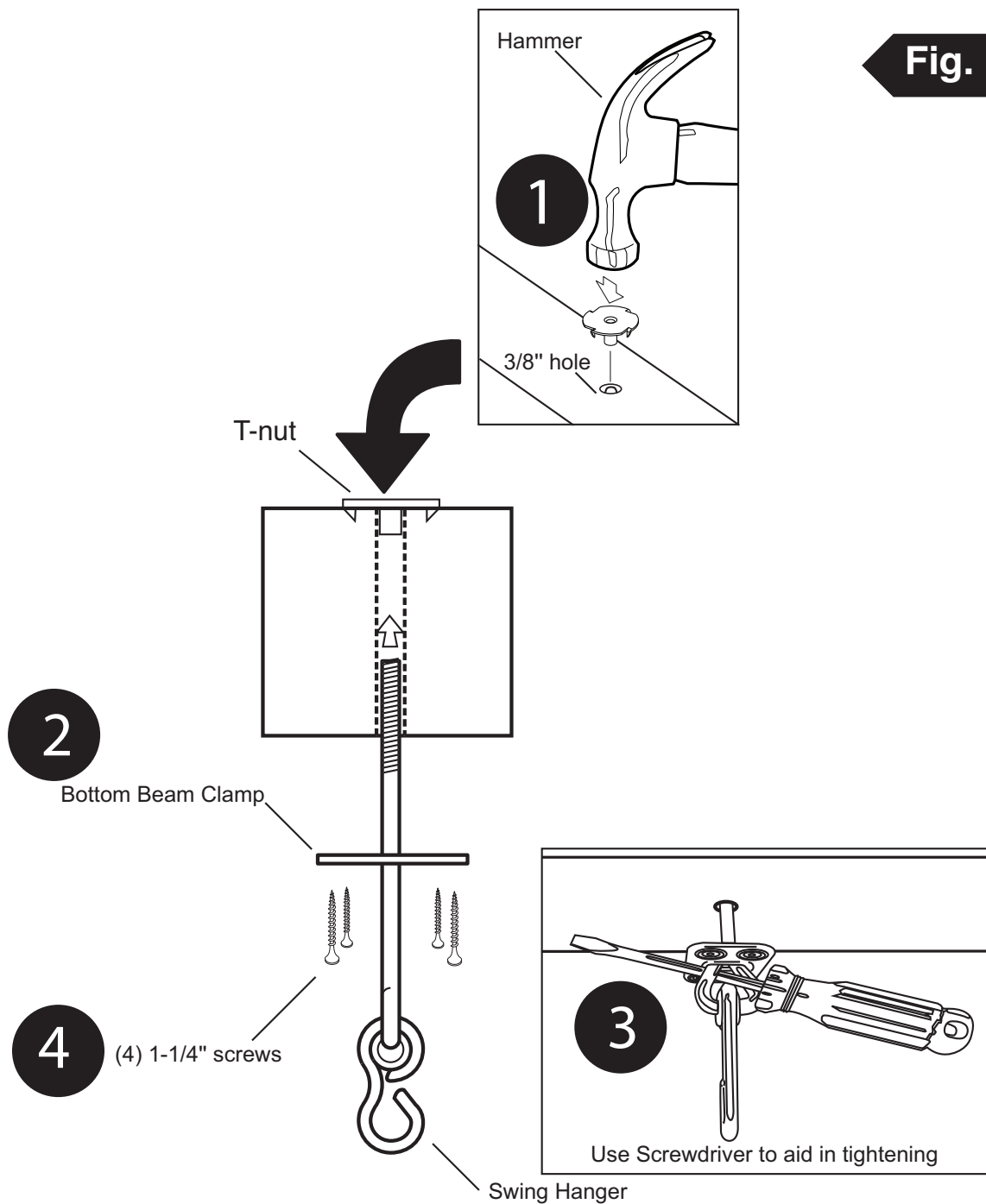
**TOP VIEW**



**playset**

# PROJECT 514

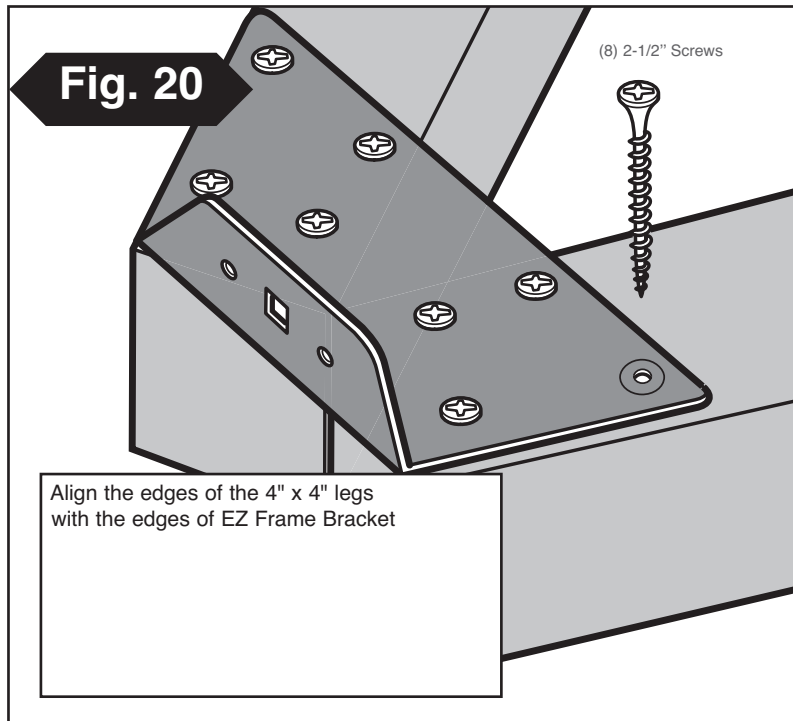
**Fig. 19**



## **Q. Swing Beam Drill Locations**

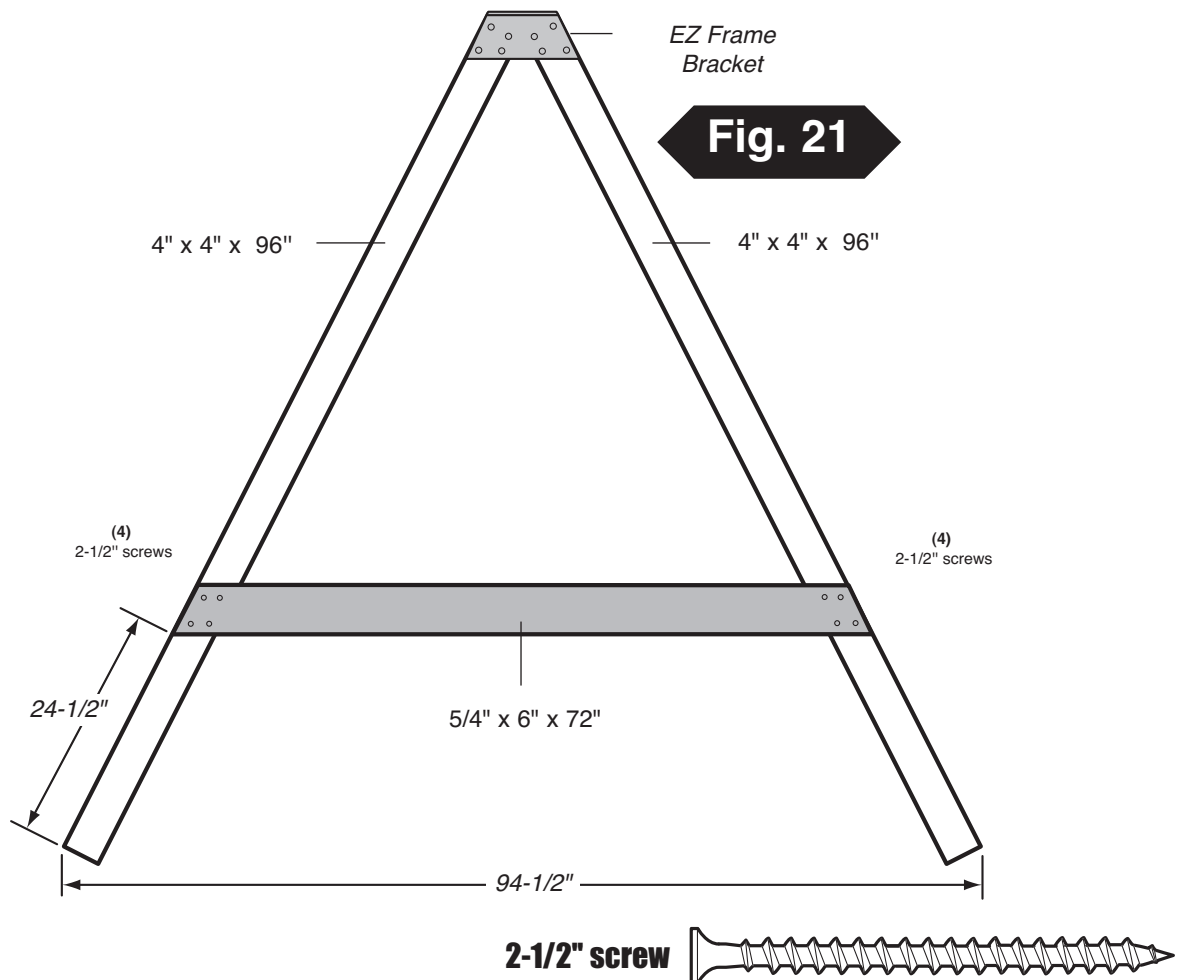
1. Tap t-nut into 3/8" hole as shown in **(Fig. 19)**
2. Place a bottom beam clamp over the swing hanger as shown in **(Fig. 19)**
3. Insert the swing hanger into the beam and thread it into the T-nut until it is flush or near flush with the top of the T-nut. A screwdriver may be used to twist the hanger **(Fig. 19)**. Orient swing hanger as shown in **(Fig 19)**.
4. Use (4) 1-1/4" screws to secure beam clamp.
5. Check hanger to ensure it does not spin.
6. Repeat for both swing hangers.



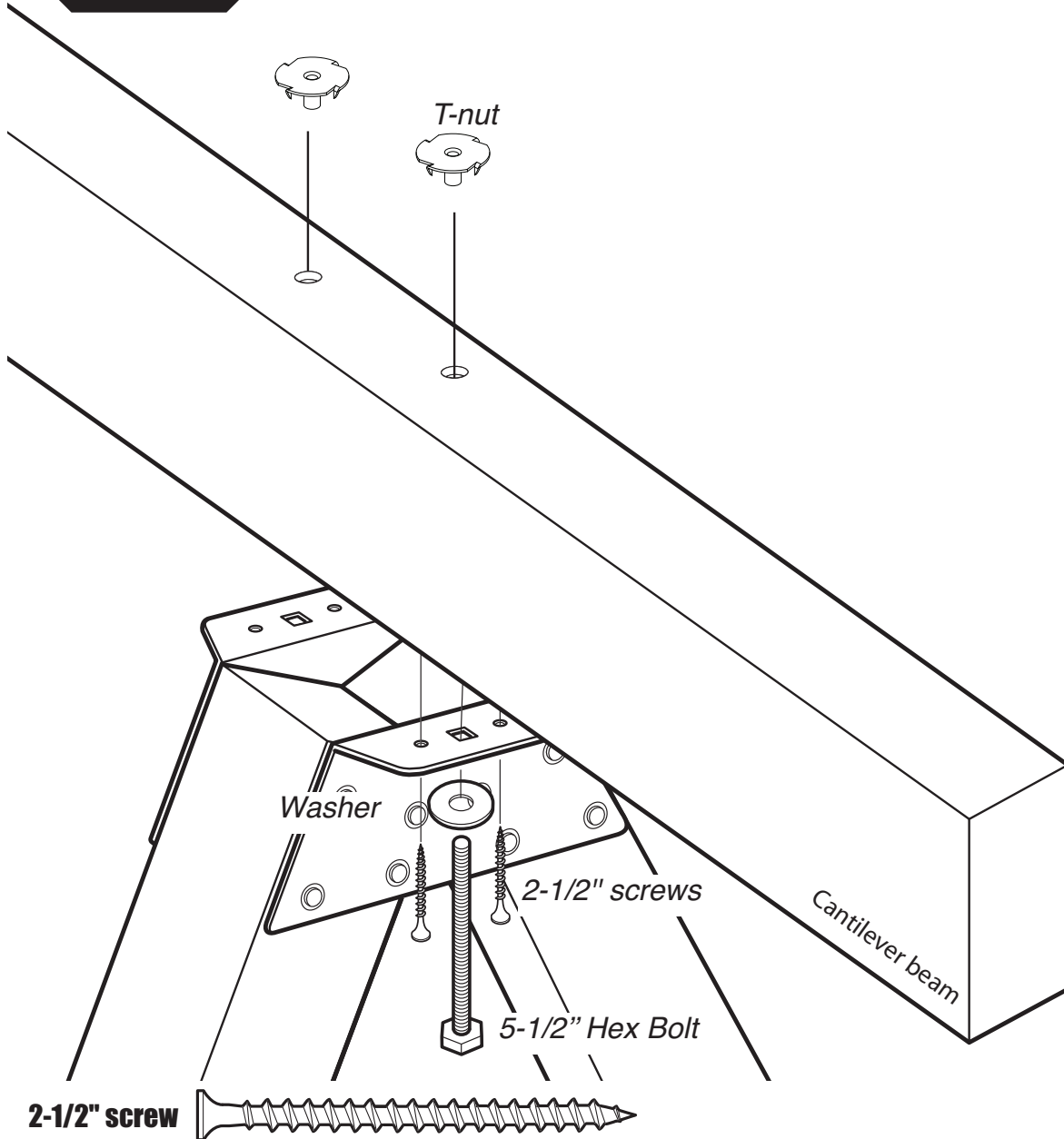


## R. A-Frame Assembly

1. layout 4" x 4"s as shown in **(Fig. 20)**
2. Align EZ Frame Bracket with face of 4" x 4"s.
3. Secure EZ Frame Bracket with (8) 2-1/2" screws to 4" x 4"s making sure they are flush with each other.
4. Secure 5/4" x 6" to 4" x 4"s as shown in **(Fig. 21)**
5. Flip over and add 2nd bracket. Repeat steps 2 and 3.



**Fig. 22**



### **S. A-Frame Assembly cont.**

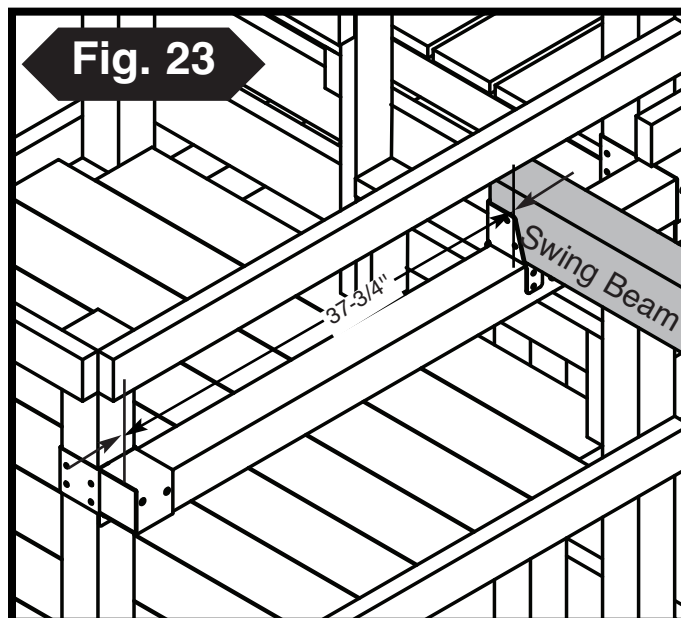
- 1. 1.** Tap T-nut into 3/8" hole as shown in **(Fig. 22)**

**Note:** If using Laminated Swing Beam, make sure T-nut teeth do not fall between seams of 2" x 6"s.

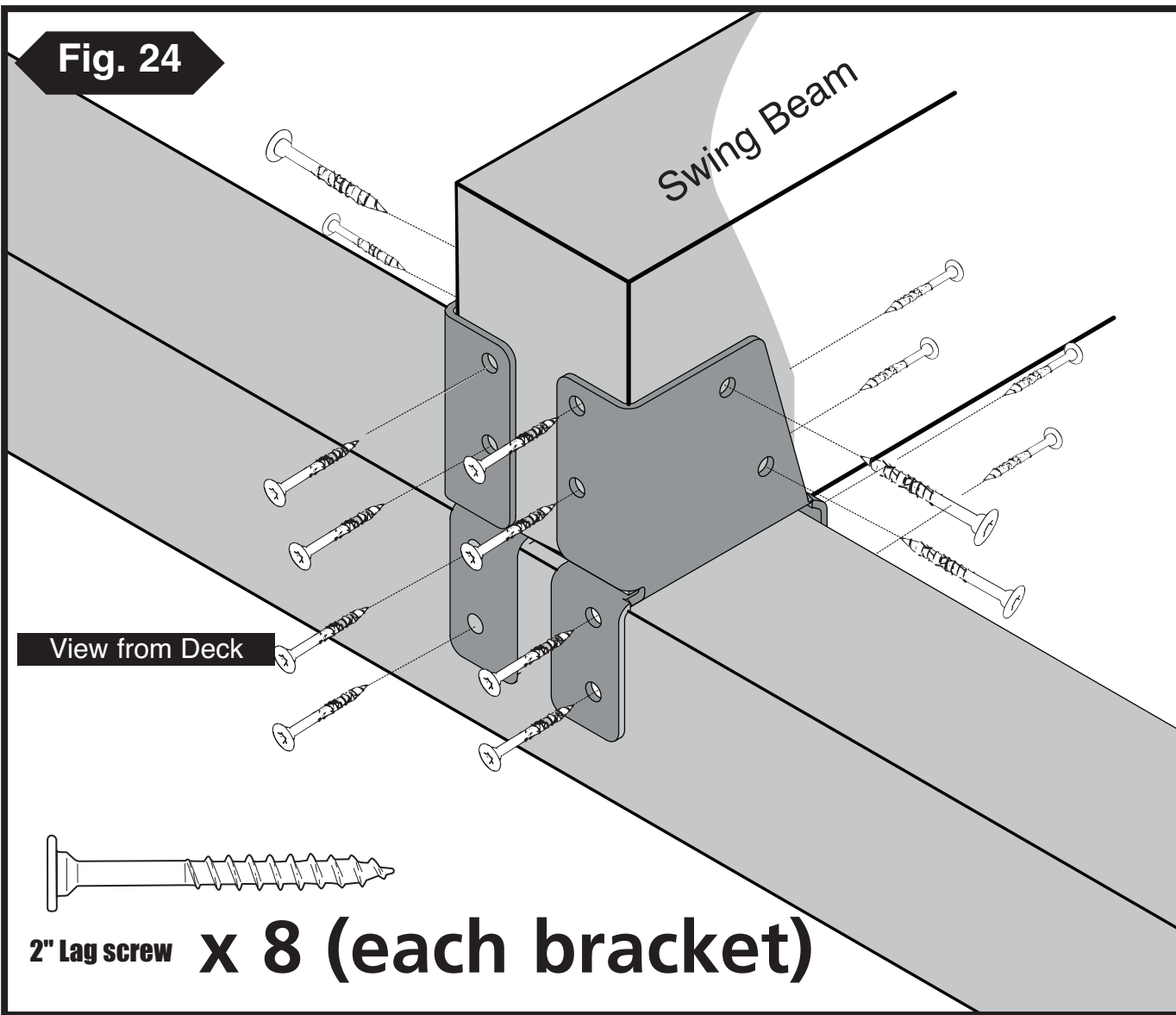
- 2.** Attach A-Frame beam to Swing Beam using (2) 5-1/2" hex bolts and 4 screws.
- 3.** Tighten hex bolt to flush with top of T-nut. Repeat on other bracket.

**T. A-Frame Assembly cont.**

1. Position Split-Brackets on 4" x 4" x 55" (Fig 23).
2. With the help of others, lift A-Frame and Swing Beam Assembly and center onto unit as shown in (Fig. 23)
3. Secure as shown in (Fig 24).

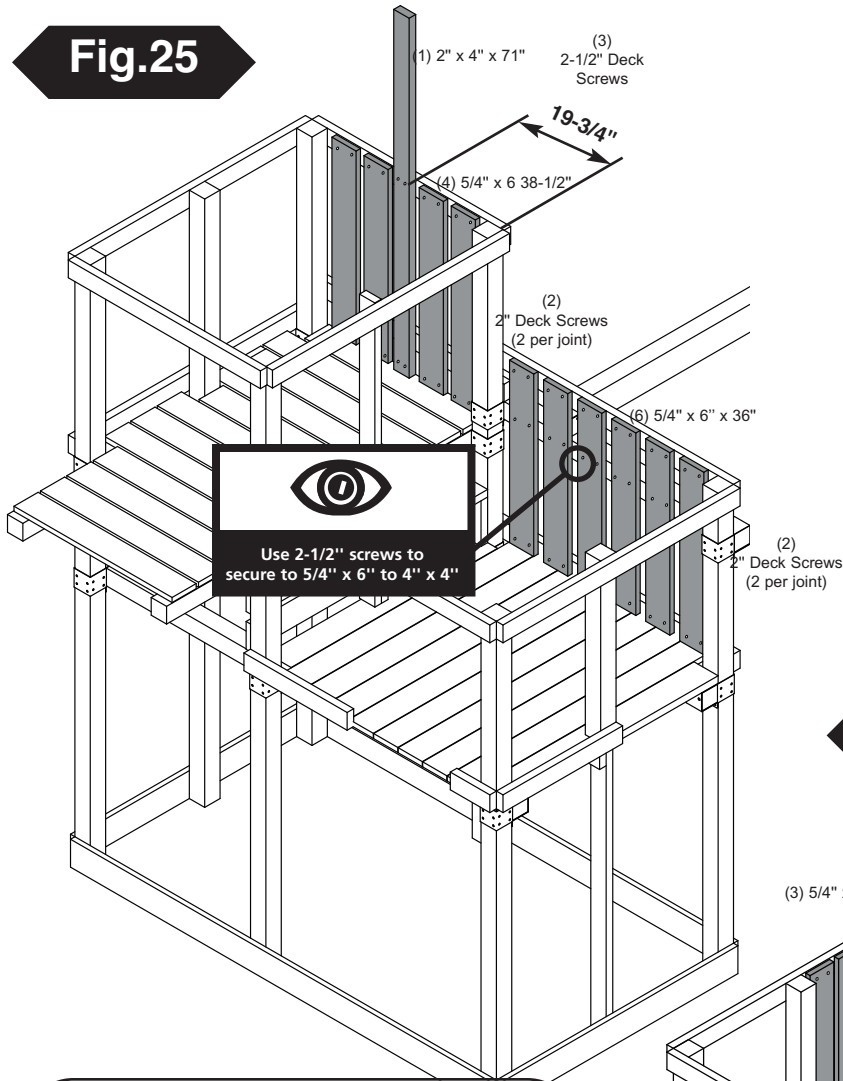


**Fig. 24**

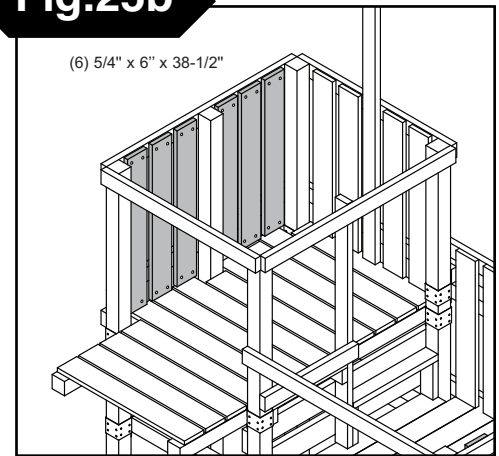


# PROJECT 514

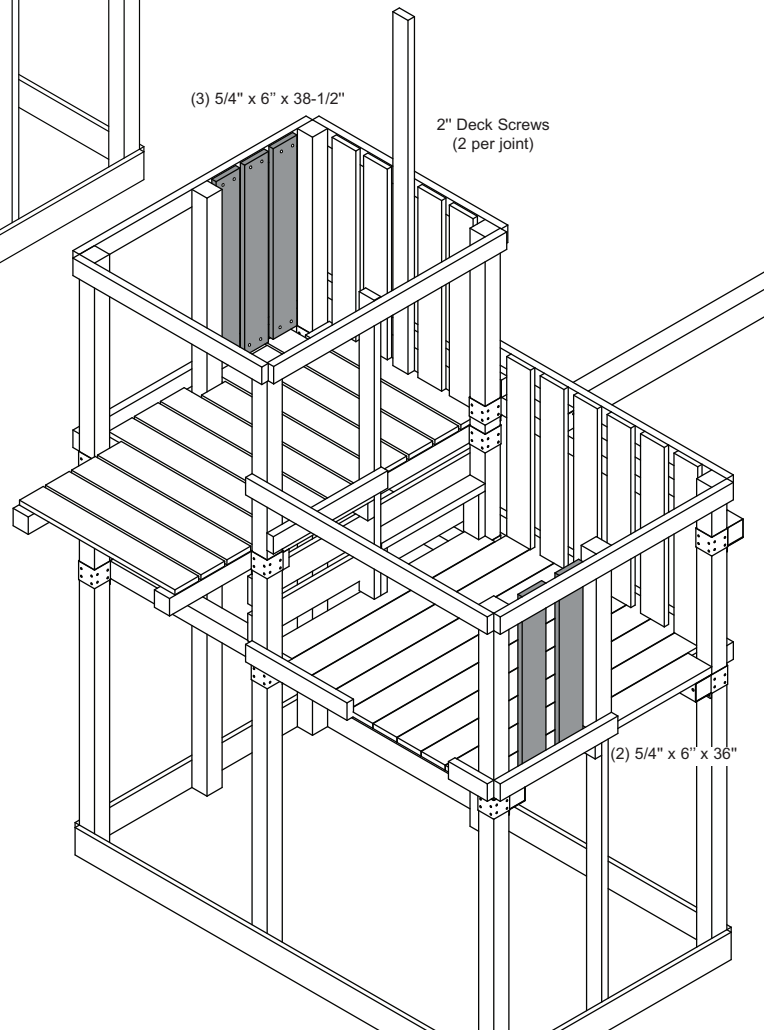
**Fig.25**



**Fig.25b**



**Fig.25a**



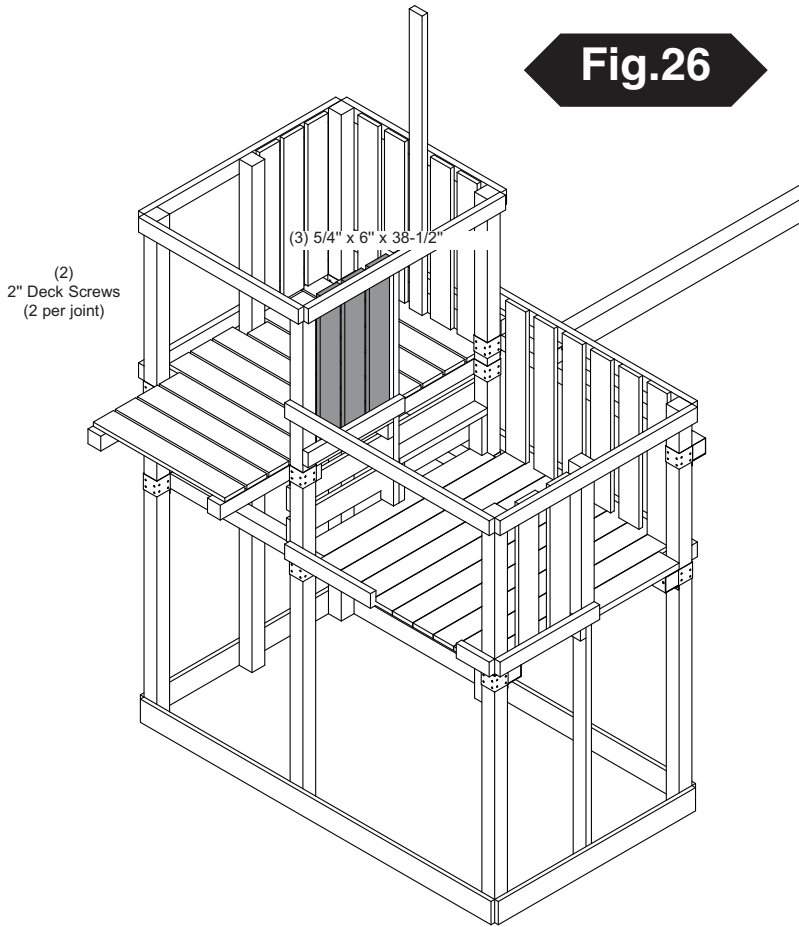
**V. Barrier Boards**

1. Install 5/4" barrier boards evenly spaced in the opening.
2. **OPTIONAL:** If an activity is not planned for this side of the unit, Install three additional 5/4" boards evenly spaced as shown in **(Fig. 25b)**.

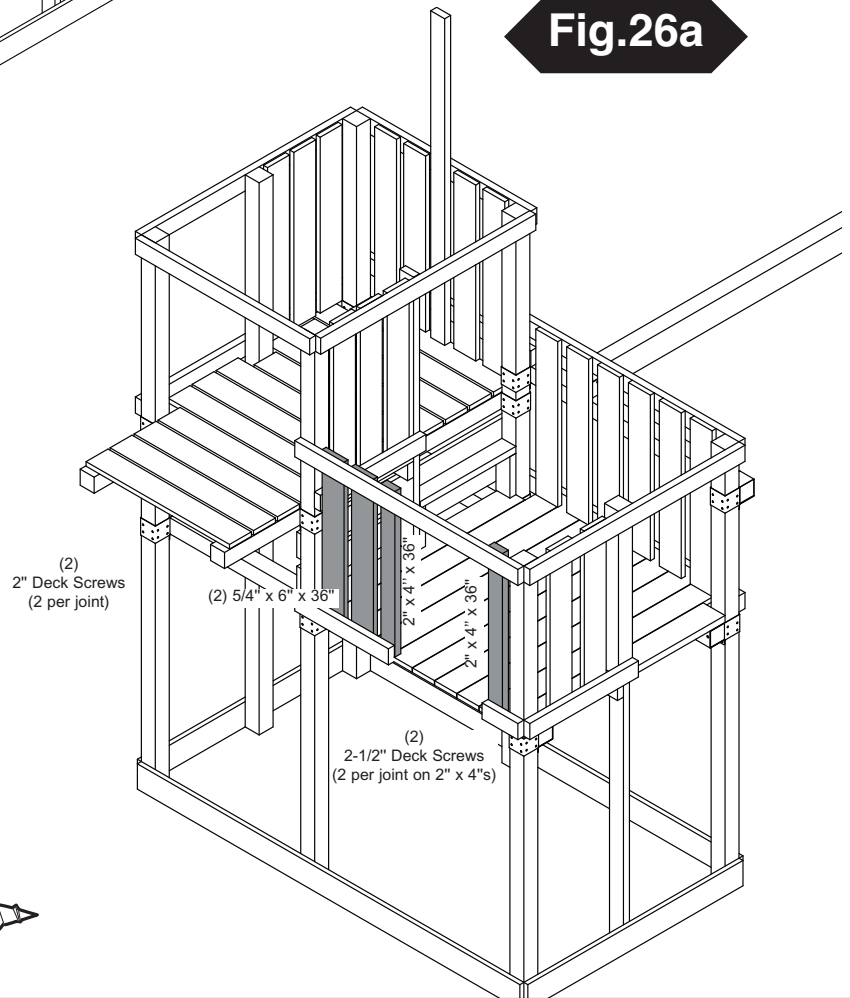
**2" screw**



**Fig.26**



**Fig.26a**



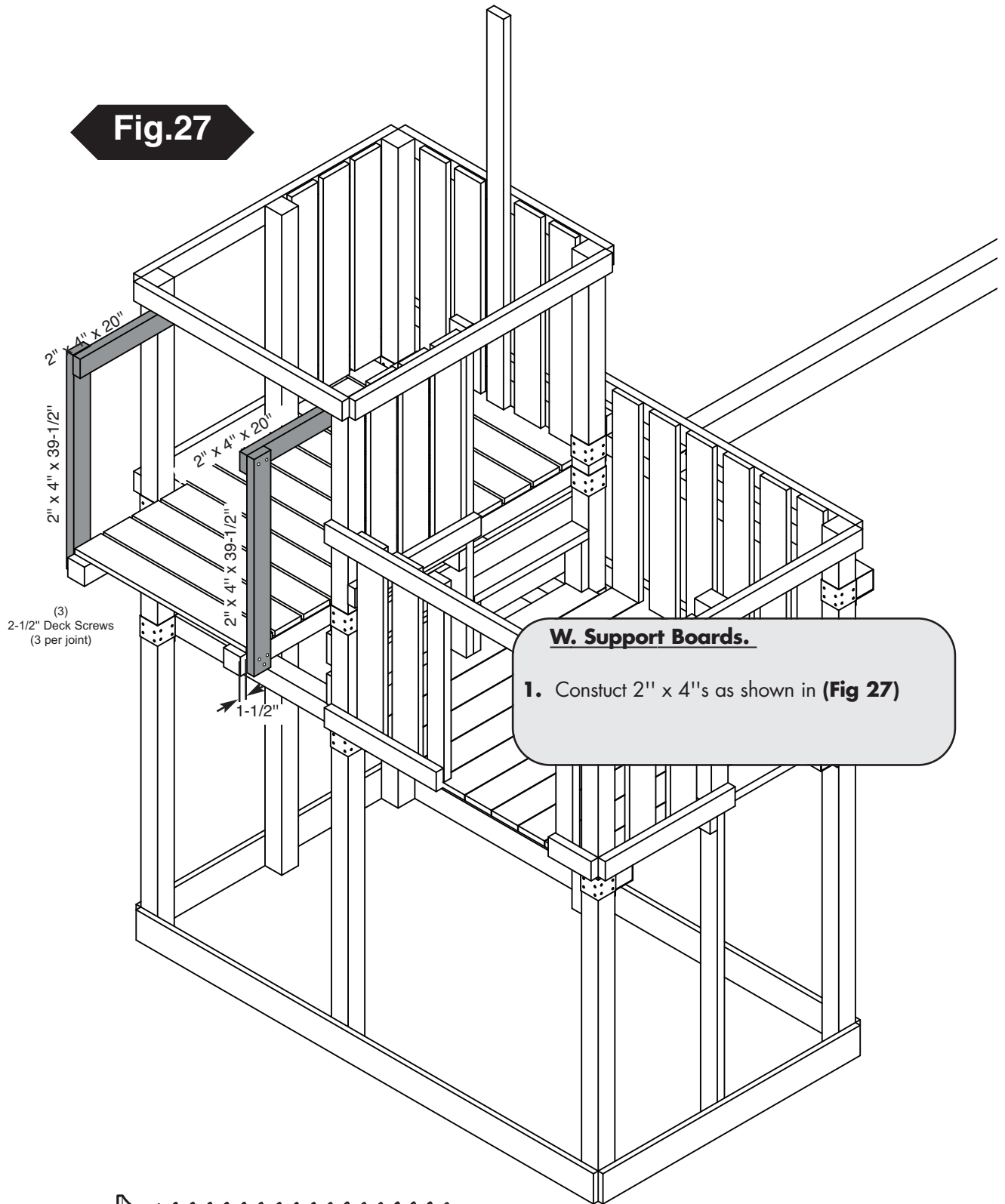
**V. Barrier Boards cont.**

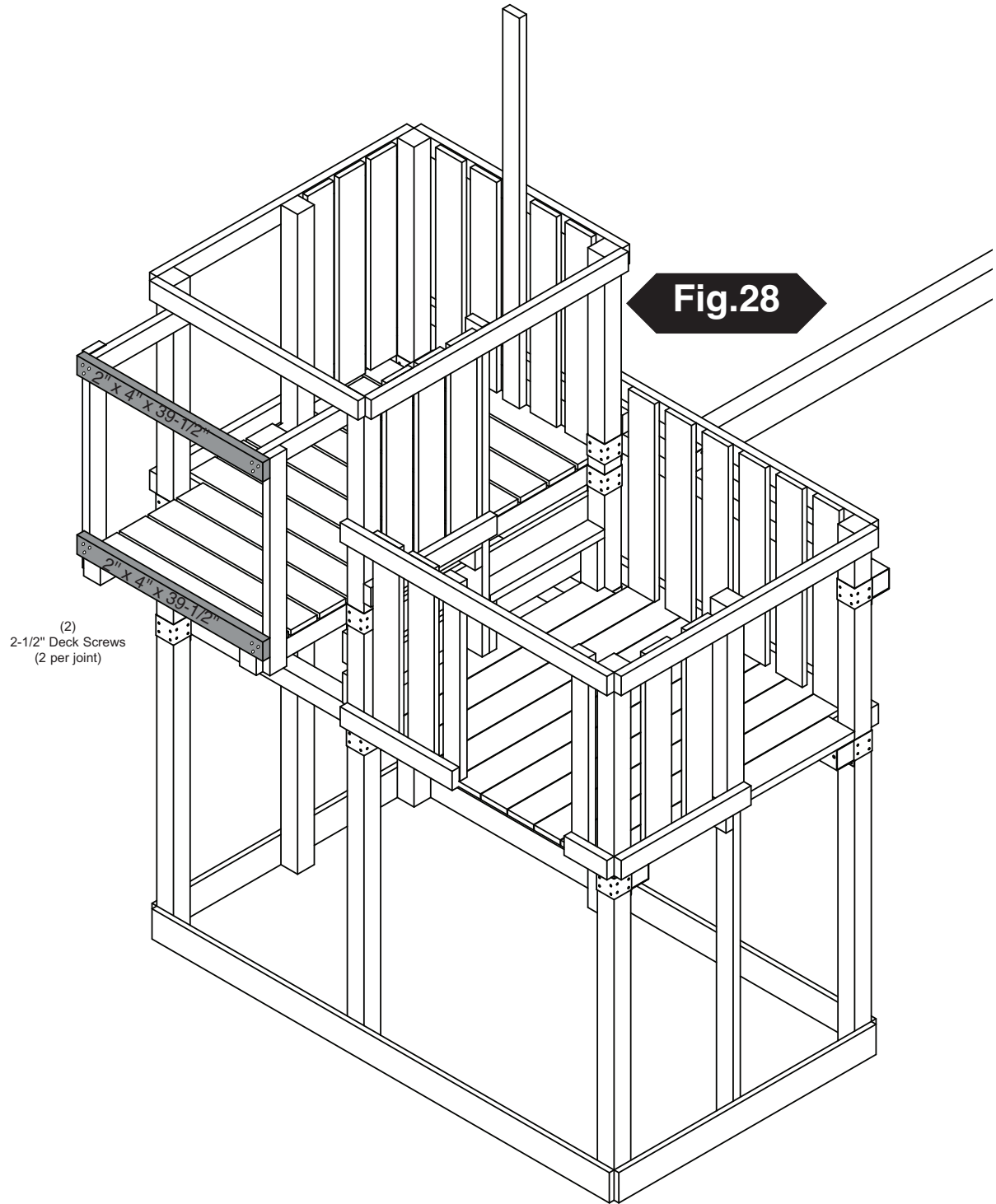
1. Install 5/4" barrier boards evenly spaced in the opening.

**2" screw**



**Fig.27**





2-1/2" screw



### W. Support Boards.

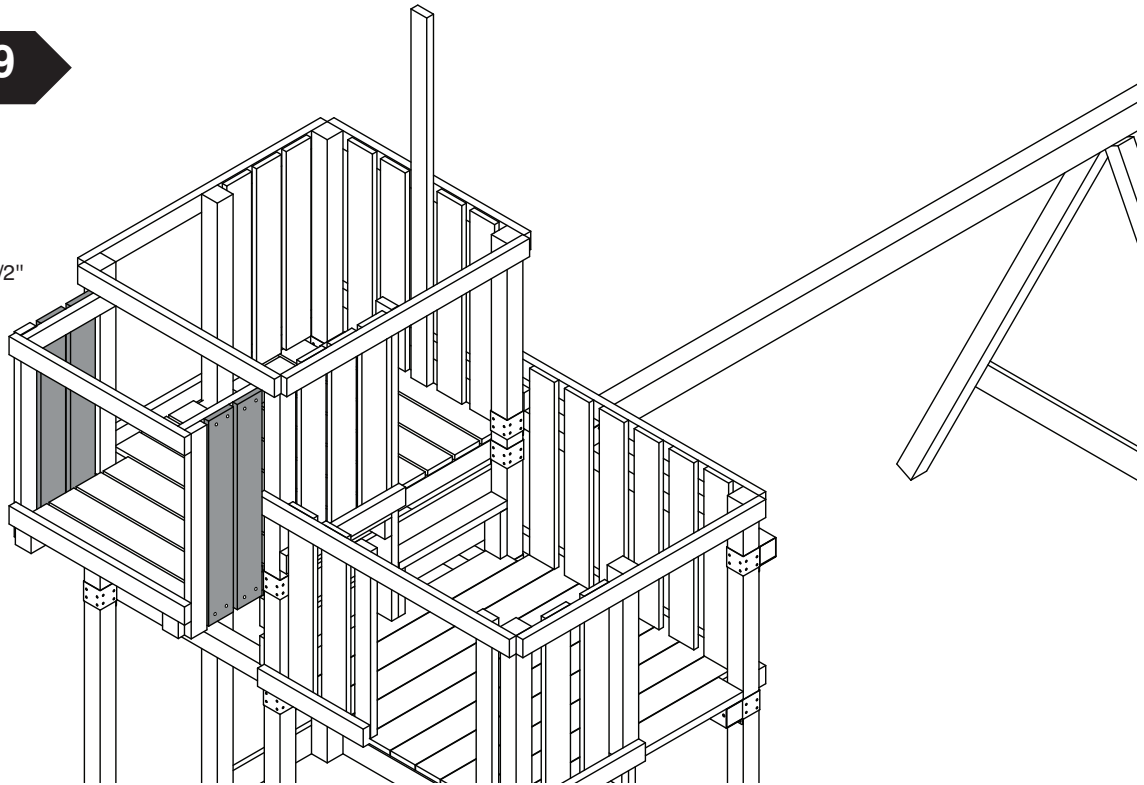
1. Construct 2" x 4"s as shown in (Fig 28)

# PROJECT 514

## Fig.29

(4) 5/4" x 6" x 39-1/2"

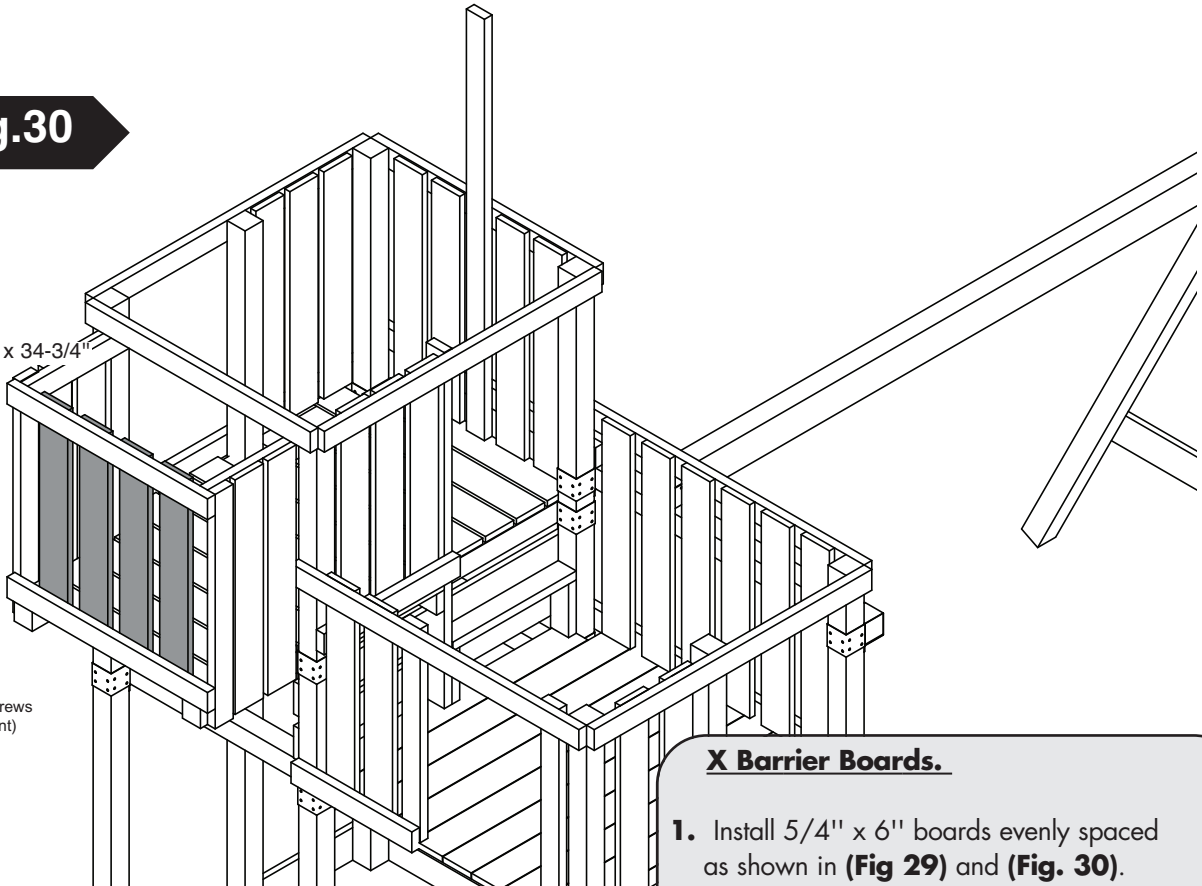
(2)  
2" Deck Screws  
(2 per joint)



## Fig.30

(4) 5/4" x 6" x 34-3/4"

(2)  
2" Deck Screws  
(2 per joint)



**2" screw**



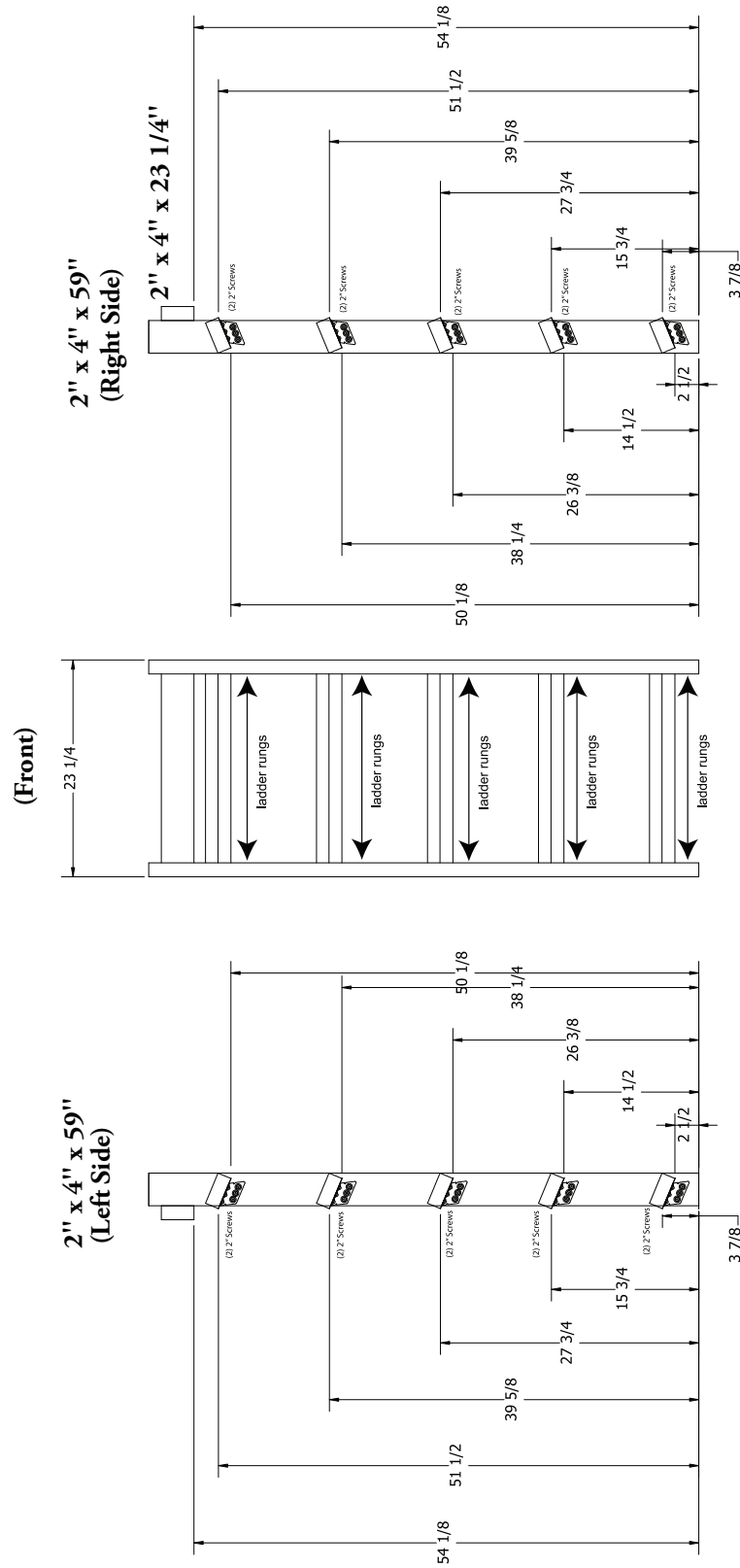
### **X Barrier Boards.**

1. Install 5/4" x 6" boards evenly spaced as shown in **(Fig 29)** and **(Fig. 30)**.



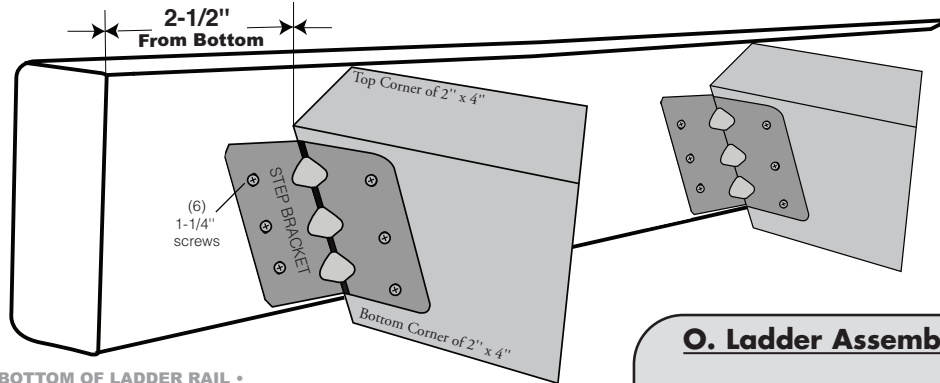
**SIDE OPENING OPTION 1**

**Fig. 31**



## SIDE OPENING OPTION 1

### EXAMPLE OF LADDER RUNG INSTALLATION



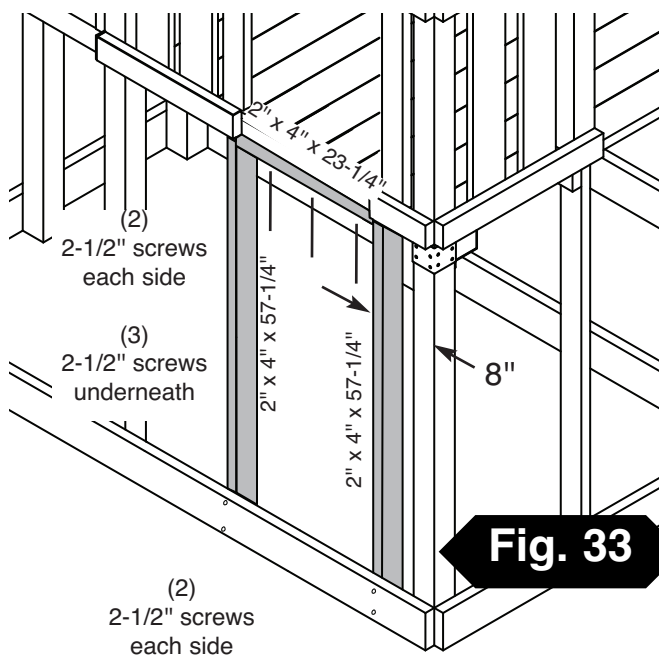
• BOTTOM OF LADDER RAIL •

**Fig. 32**

### O. Ladder Assembly.

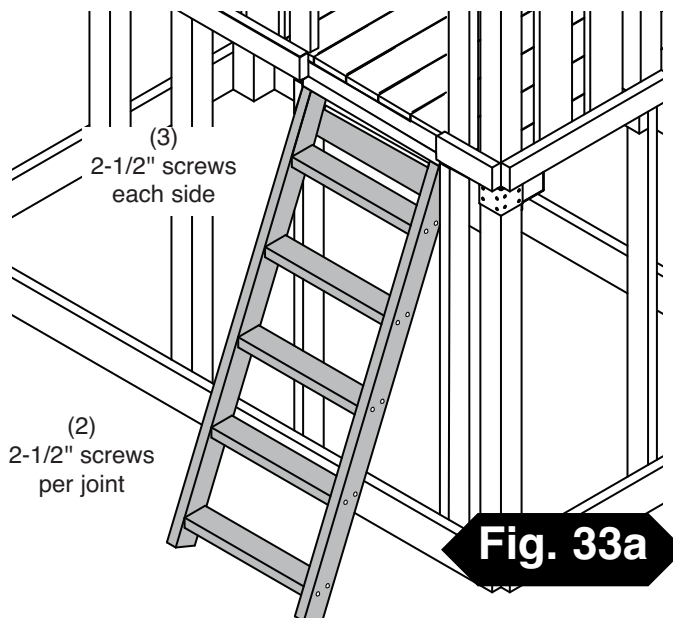
1. On ladder rails, mark all measurement locations for each side with a pencil. Draw an angle line connecting measurements for each ladder rung alignment. (**Fig. 31**)
2. Align top of step bracket with line and screw in place. Install a ladder rung at each of the four locations. (**Fig. 31**) and (**Fig. 32**) Repeat on other ladder rail.
3. Attach 2" x 4" x 23-1/4" to siderails using (2) 2-1/2" screws per side.
4. Secure ladder to unit. (**Fig. 33**) and (**Fig. 33a**)  
**Note:** The top step should be 11" below the deck and all steps should be level.
5. Screw (2) 2-1/2" screws into the ends of each ladder rung through the left and right side rails. (**Fig. 31**)

(6) 1-1/4" screws



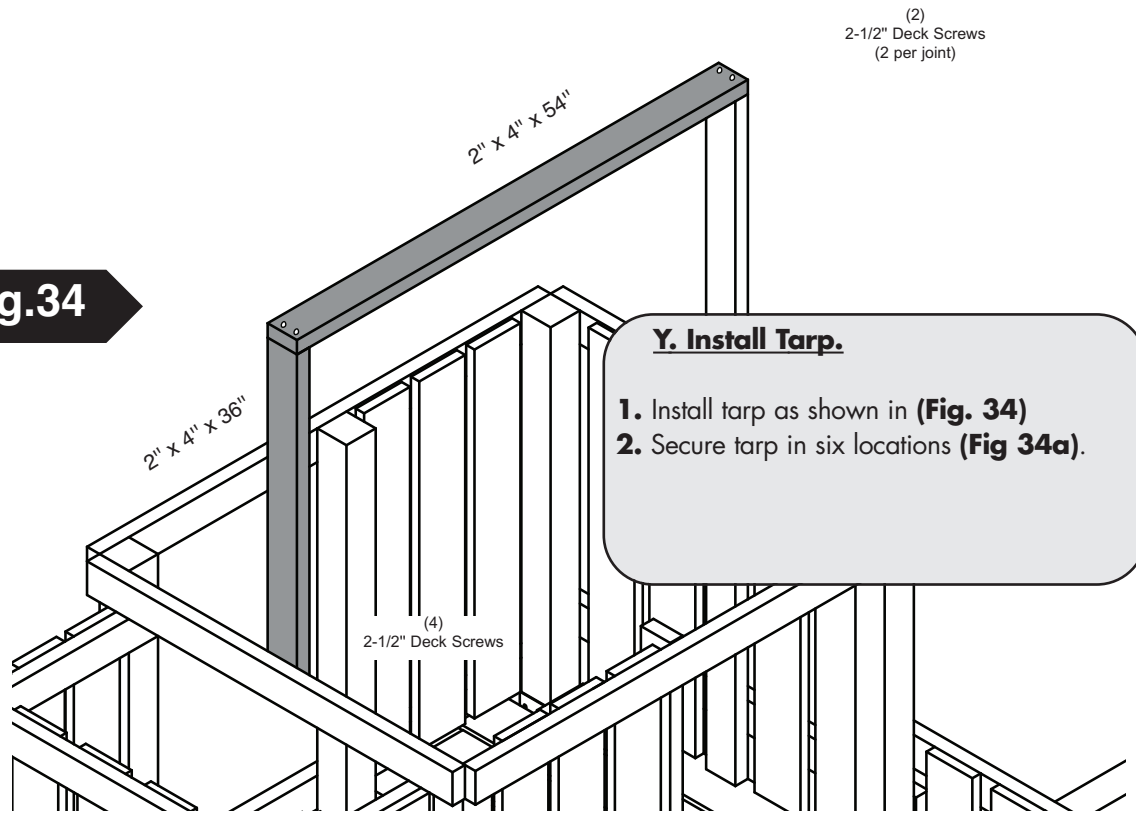
**Fig. 33**

2-1/2" screw

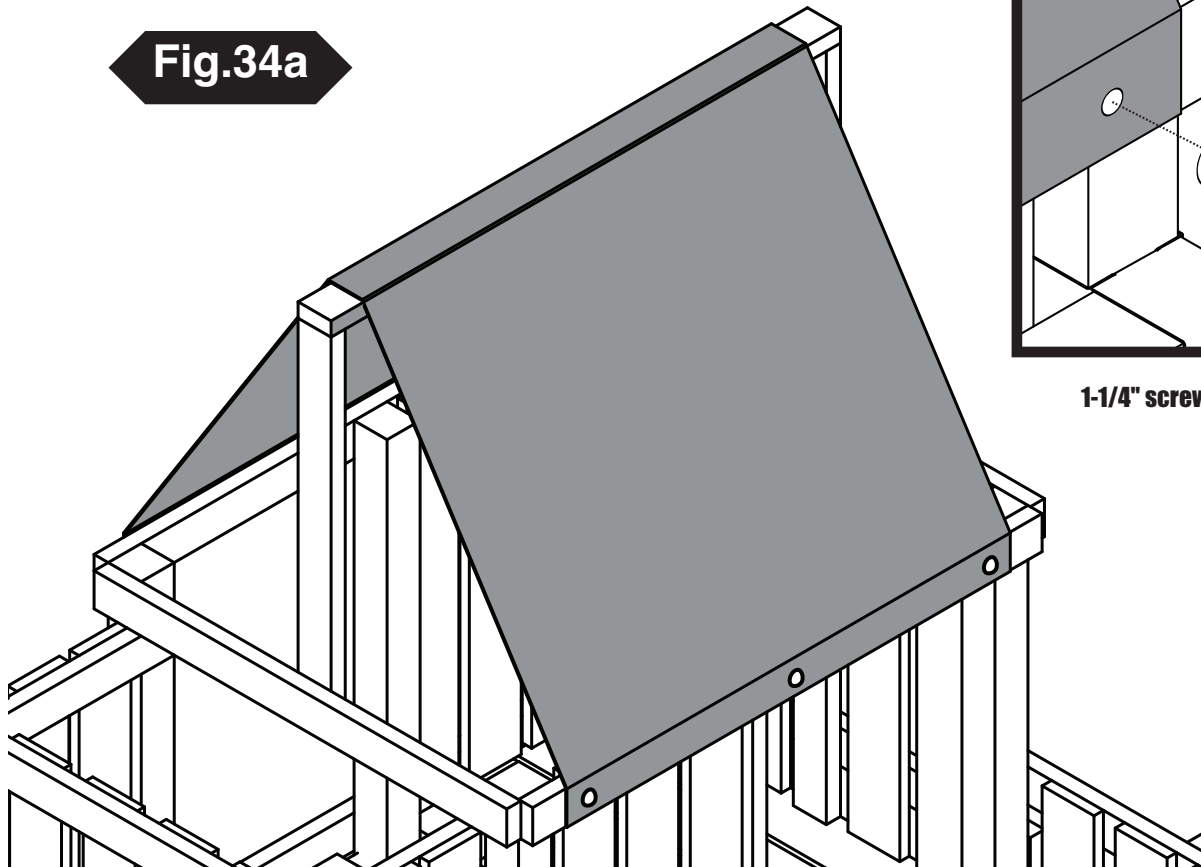
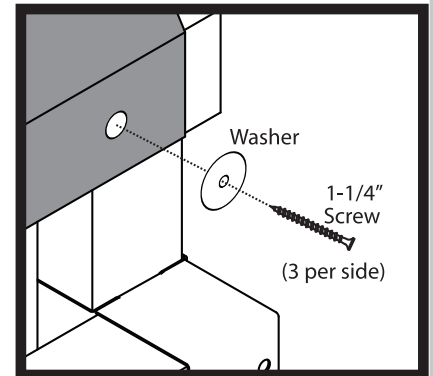


**Fig. 33a**

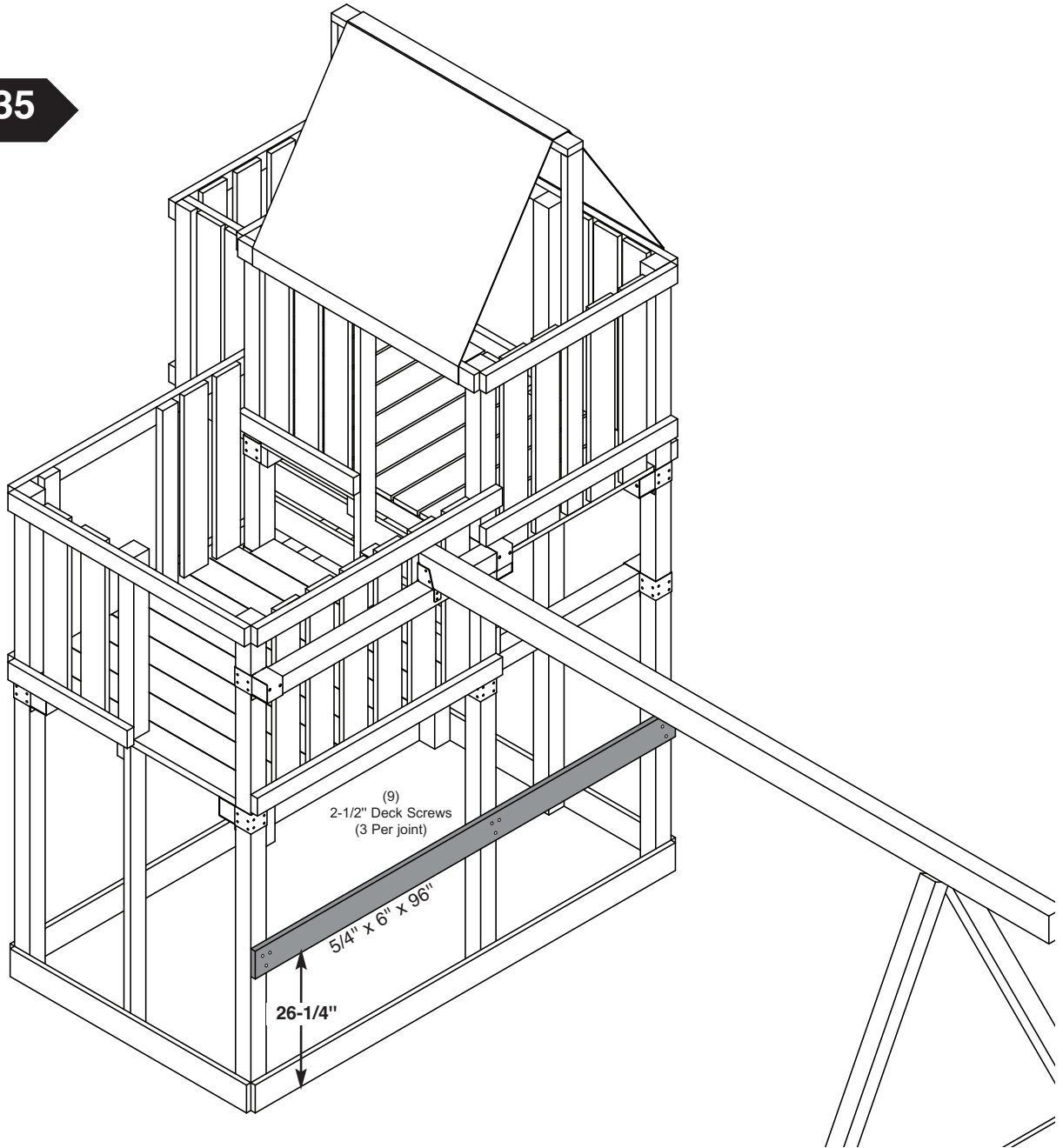
**Fig.34**



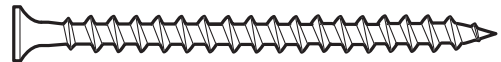
**Fig.34a**



**Fig. 35**



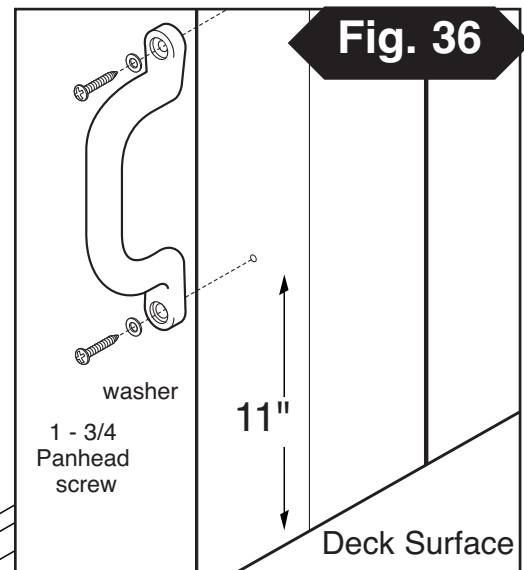
**2-1/2" screw**



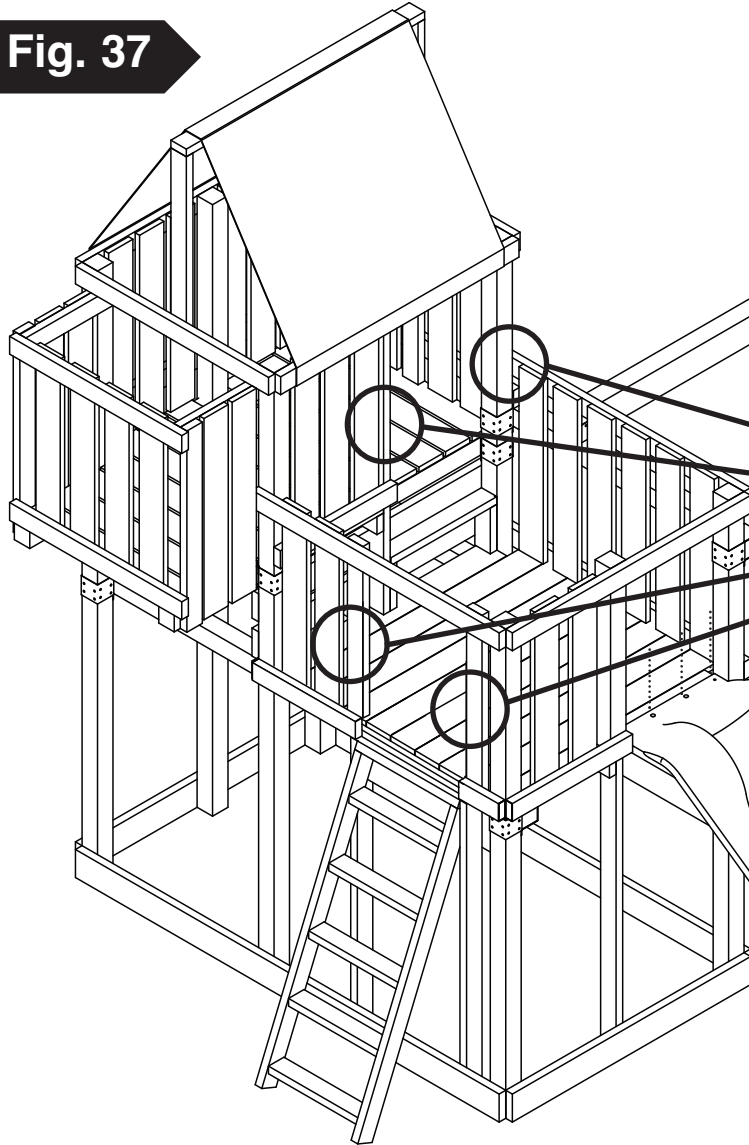
### **Z1. Install Protective Barrier Board**

- 1.** Secure protective 5/4" barrier board as shown in **(Fig 35)**.

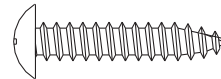
**Fig. 36**



**Fig. 37**



**INSTALL PLAY HANDLES  
HERE**



**1" Truss Screw**  
Use truss head screws to  
to secure slide to deck.

**Slide/Safety Handle  
Installation.**

1. Mount safety handles in the ladder opening approximately 11" above the deck surface (**Fig. 36**).
2. Install Slide as shown in (**Fig. 37**)

**Important:**

**Do not use hardware provided with slide. Use Truss head screws included with Kit.**

THIS PRODUCT IS  
INTENDED FOR USE  
BY CHILDREN FROM  
AGES 2-10 YEARS

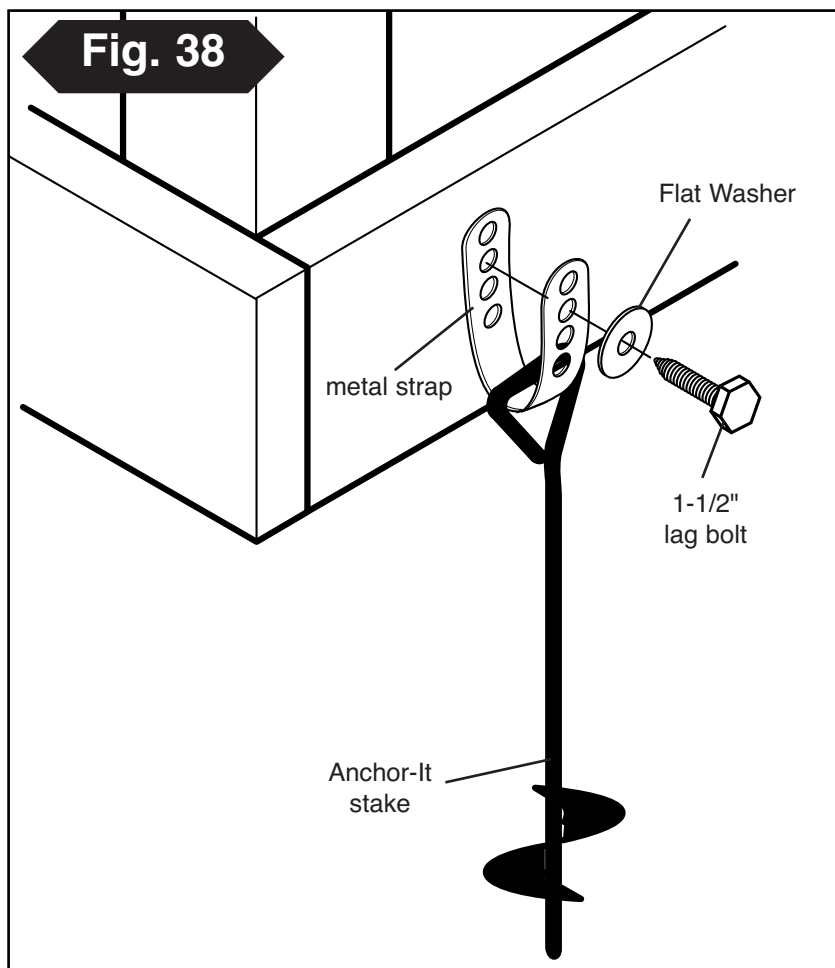
For Home / Residential  
Use ONLY

**Swing-A-Slide**

1212 Barbary Drive  
Janesville, WI 53545  
1-800-888-1232  
www

**Secure your product ID tag onto easy  
to read location of any 4" x 4"  
using (2) 2" screws**

## Anchor-It (Sold Separately)

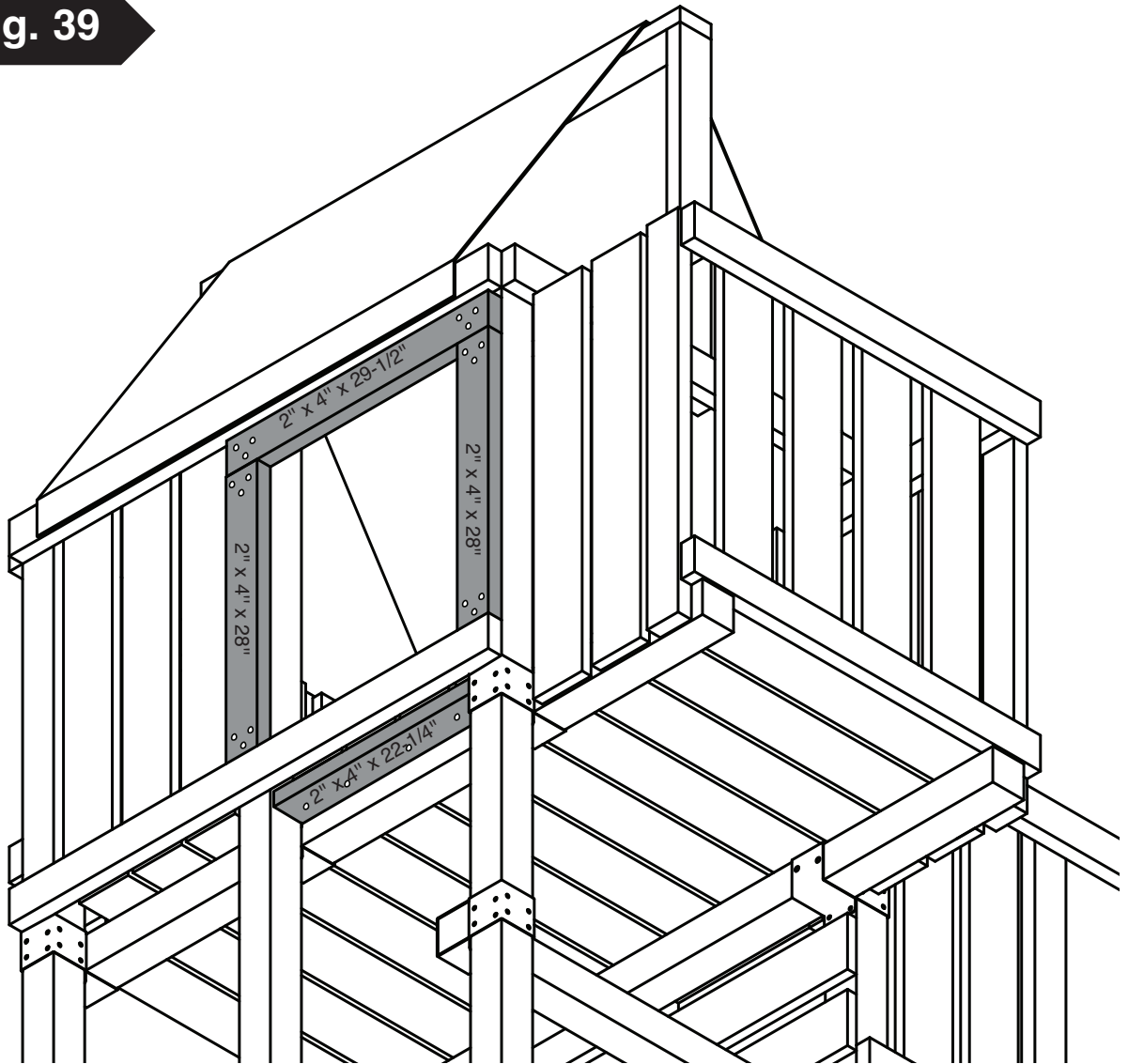


### **S. Anchor-It Installation (optional).**

#### **Instructions for Anchoring Swing•N•Slide Activity Centers**

1. Determine the final location of your activity center.
2. Place the Anchor-It stakes adjacent to the base and near the corners of your activity center (at the bottom of the legs on swing sets) and twist the auger-style stakes into the ground until only the loop is exposed.
3. Place the metal strap through the loop of the Anchor-It stake and secure it to the unit with a lag screw and washer as illustrated to the right. Note: Attach the strap to the unit with as little play as possible using whatever holes in the strap that work best.

Fig. 39



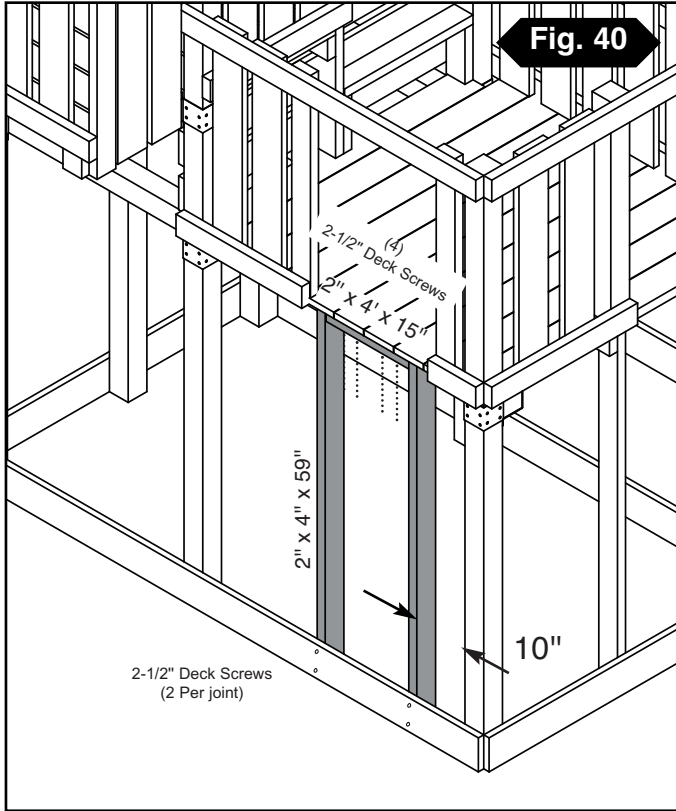
2-1/2" screw



**A2. Unit Modification cont.**

- (1) Install 2" x 4" frame and support as shown in (Fig. 39).

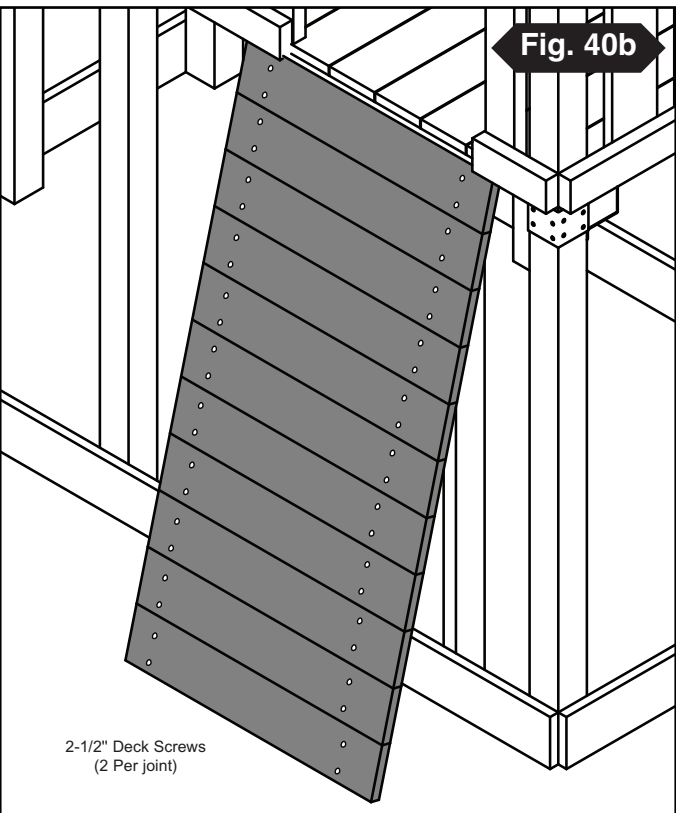
# PROJECT 514



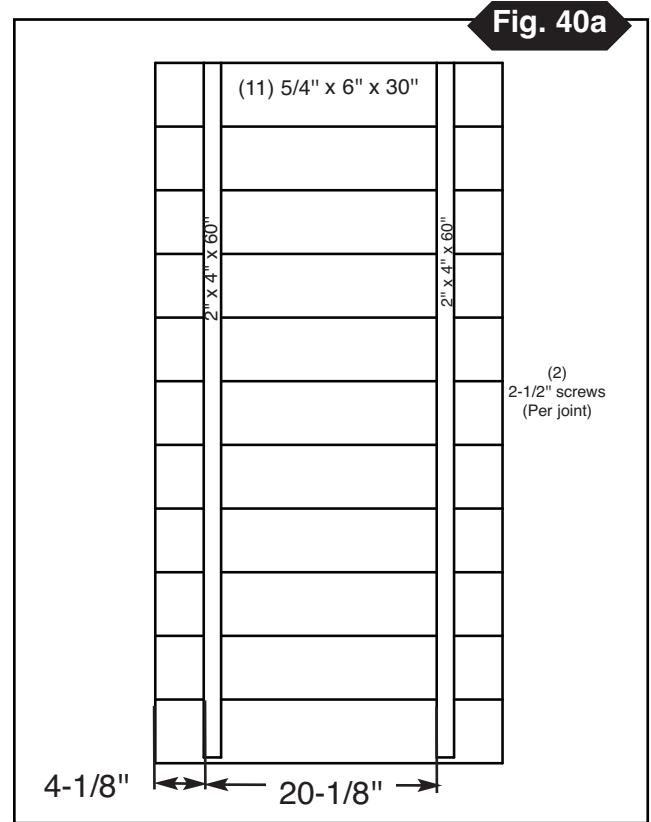
2-1/2" Deck Screws  
(2 Per joint)



**2-1/2" screw**



2-1/2" Deck Screws  
(2 Per joint)



(11) 5/4" x 6" x 30"

2" x 4" x 60"

2" x 4" x 60"

(2)  
2-1/2" screws  
(Per joint)

4-1/8" 20-1/8"

**NOTE:**  
5' Climbing Rock Wall will require  
**Min. 12 Climbing Rocks**  
(3) Bags of NE 4543S Climbing Rocks.

**Climbing Wall Lumber Cut List.**

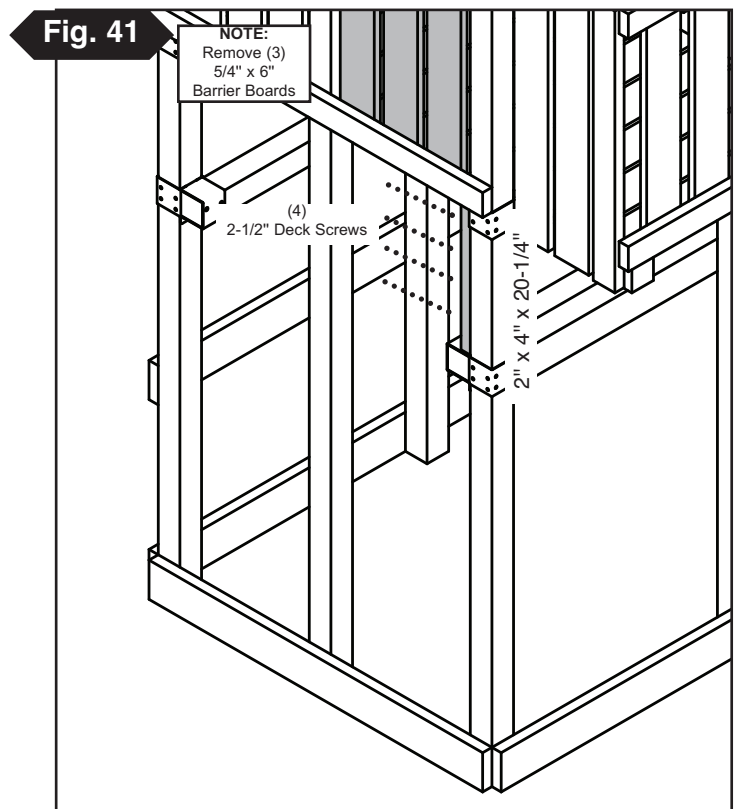
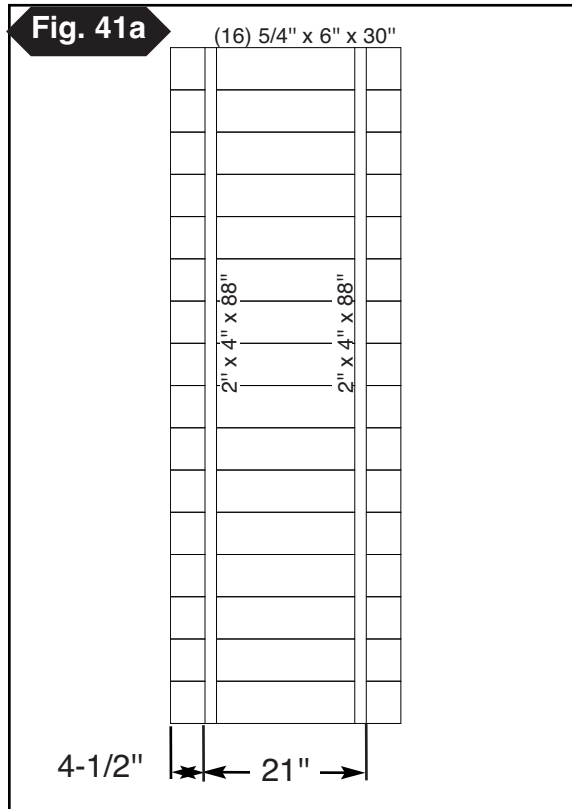
- (1) 2x4x96 ----- (1) 2x4x59 (1) 2x4x15
- (1) 2x4x96 ----- (1) 2x4x59
- (1) 2x4x120 ----- (2) 2x4x60
- (3) 5/4x6x120 - (4) 5/4x6x30

1. Assemble and install Climbing Wall Frame as shown in (Fig. 40), (Fig. 40a).
2. Attach (11) 5/4" x 6" boards to (2) 2" x 4" boards and install on unit as shown in (Fig. 40b).
3. Secure Rock Wall to unit using (3) 2-1/2" screws per side.

**Note:** Make sure the 2" x 4" supports do not interfere with the mounting of the climbing rocks.



## BACK OPENING OPTION 2



**2-1/2" screw**

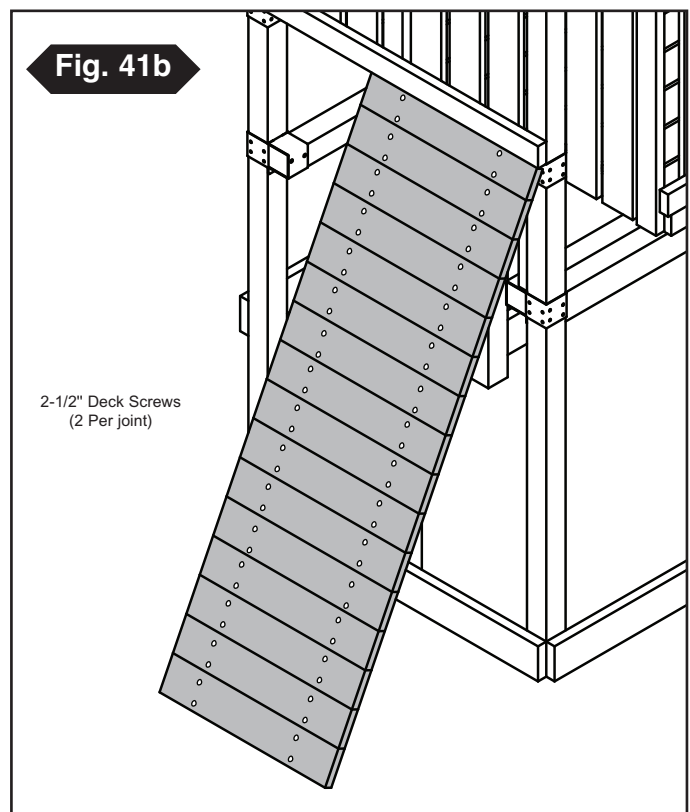
**NOTE:**  
7' Climbing Rock Wall will require  
**16 Climbing Rocks**  
(4) Bags of NE 4543S Climbing Rocks.

**Climbing Wall Lumber Cut List.**

- (1) 2x4x96 ----- (1) 2x4x88
- (1) 2x4x120 ----- (1) 2x4x88 (1) 2x4x20-1/4
- (4) 5/4x6x120 --- (4) 5/4x6x30

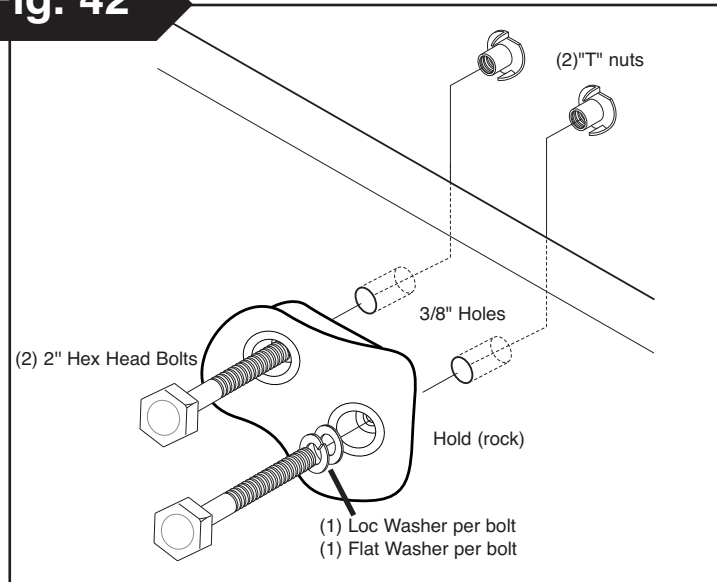
1. Assemble and install Climbing Wall Frame as shown in **(Fig. 41), (Fig. 41a)**.
2. Attach (16) 5/4" x 6" boards to (2) 2" x 4" boards and install on unit as shown in **(Fig. 41b)**.
3. Secure Rock Wall to unit using (3) 2-1/2" screws per side.

**Note:** Make sure the 2" x 4" supports do not interfere with the mounting of the climbing rocks.



## *Climbing Rock*

**Fig. 42**



### **Climbing Rock Installation**

- 1.** Mark locations of Climbing Rocks on the Climbing Wall in a pattern that will easily allow your child to climb to the deck. Make sure the bolt hole locations are clear of wall supports before drilling.
- 2.** Drill holes through the wall at the desired locations using a 3/8" drill bit. Install Climbing Rocks as shown in **(Fig. 42)**.
- 3.** Make sure the Climbing Wall and Climbing Rock connections are secure before allowing any children to play on the Climbing Wall.



***Questions???***  
***Call our Customer Service Department***  
***at 1-800-888-1232***



We Put Kids First.